

INSTR. NUMBER	PG.	REV.	ITEM NO.	PART NUMBER	DESCRIPTION	QTY.
: 66983	1	A	1	EP1650TLL	END PANEL, FORD LR, 16X50, GRAY	1
			2	EP1650TLR	END PANEL, FORD LR, 16X50, GRAY	1
PART NUMBER : HD-1660TL			3	SF21660X-G	SHELF, STD, 2X16X60, GRAY	3
PART • 16" SHELVING, 60" WIDTH DESC. •			4	SF21260X-G	SHELF, STD, 2X12X60, GRAY	1
			5	HDW66983	HARDWARE KIT FOR LOW ROOF 16 INCH SHELVING	1

THIS INSTRUCTION IS FOR ALL SHELVING VARIATIONS OF THE LOW ROOF 16" DEEP SHELVING. THIS INCLUDES 60" (HD-1660TL SHOWN BELOW), 50", 44", 40", AND 32". ADDITIONALLY, THIS INSTRUCTION COVERS THE INSTALLATION OF THE CONDUIT CARRIER VARIATION OF THE SHELVING. THE INSTALLATION OF THESE SHELVES IS NOT DEPENDANT ON THE SHELF LENGTH OR IF THE END PANELS HAVE THE CONDUIT CARRIER ACCESS HOLE. SEE PAGE 3-6 FOR A BREAKDOWN OF ALTERNATE SHELVING UNITS.

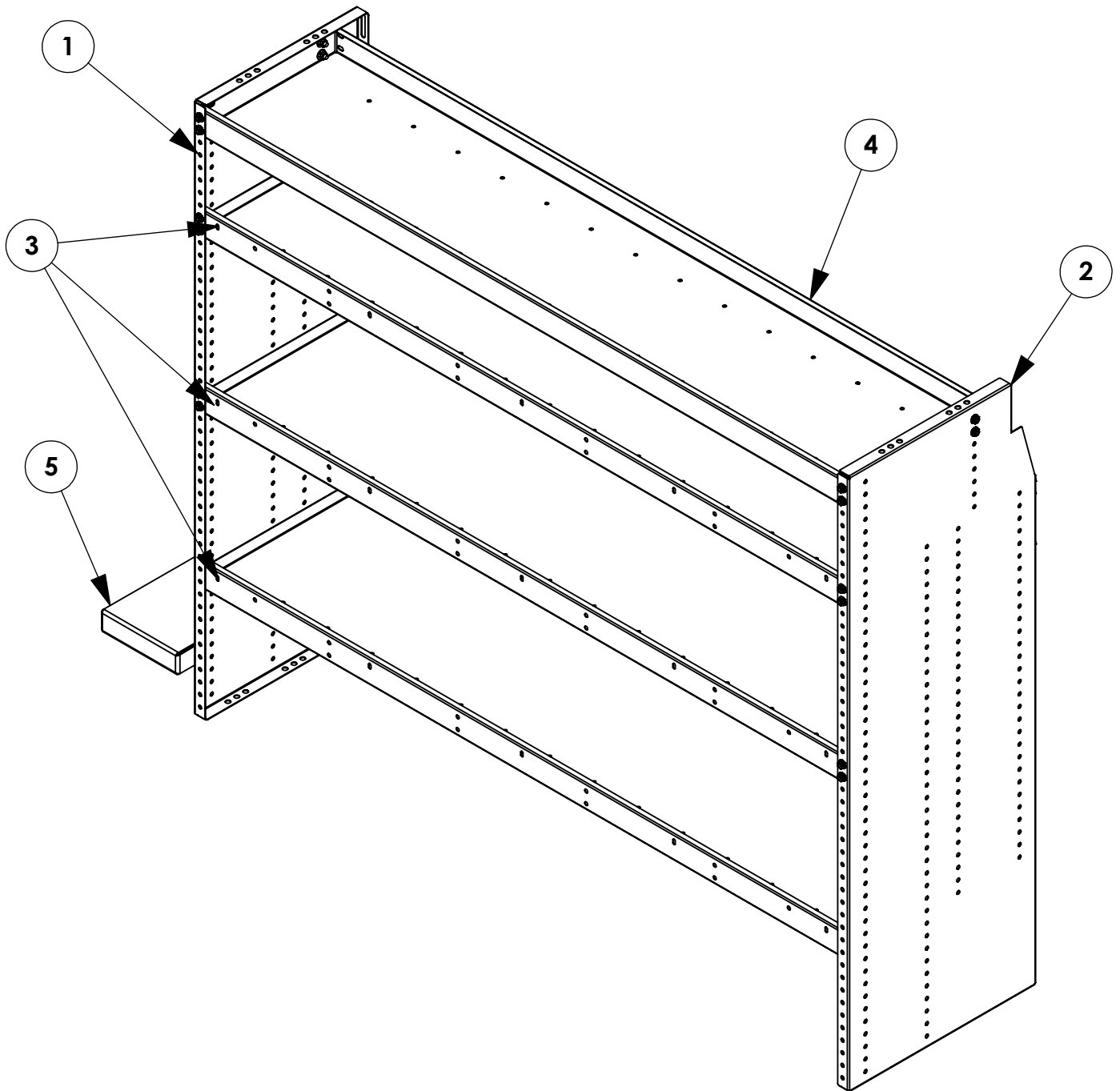

GET TO KNOW THE VEHICLE - AT THE BEGINNING OF ANY INSTALLATION, CHECK THE LOCATION OF THE FUEL TANK, FUEL LINES, BRAKE LINES, HIGH VOLTAGE BATTERIES AND WIRING HARNESES TO AVOID INJURY OR PROPERTY DAMAGE FROM TOOL CONTACT.

SEAL ALL EXTERIOR HOLES - ALL INSTALLATION HOLES SHOULD BE SEALED WITH BUTYL TAPE OR SILICON TO PREVENT WATER AND EXHAUST GASES FROM ENTERING THE VEHICLE.

CONTROL DRILL DEPTH - TO AVOID DAMAGE TO THE VEHICLE, USE A DRILL STOP OR CLEARED STEP BIT WHEN DRILLING INSTALLATION HOLES.

ALWAYS ADD PRIMER - WHEN ADDING INSTALLATION HOLES BE SURE TO USE A SELF-ETCHING PRIMER TO PREVENT CORROSION, FASTENER FAILURE AND INJURY.

MOUNTING POINTS MUST HAVE METAL-TO-METAL CONTACT - USE PROVIDED MOUNTING SPACERS TO ACCOMMODATE FOR VEHICLE FEATURES, CARPET OR SUBFLOORS.

PROVIDE CLEARANCE FOR SPACERS - IF THE INSTALLATION VEHICLE CONTAINS A CARPET OR SUBFLOOR, USE A 1-3/16" DIAMETER CARPET CUTTER (P/N: 31183-0) AT ALL MOUNTING LOCATIONS TO OPEN UP ROOM FOR SPACERS.

CHECK SPACER ORIENTATION - BE SURE THAT THE INDENT IN THE SPACER COVERS THE PLUSNUT HEAD; THIS ENSURES THE MOST METAL-TO-METAL CONTACT AND REDUCES VIBRATION.

PLUSNUT INSTALLATION - A PLUSNUT GUN IS RECOMMENDED FOR PLUSNUT INSTALLATION FOR ITS PRODUCTION SPEED. HOWEVER, A PLUSNUT SETTING TOOL CAN ALSO BE USED (P/N: 22200-0).

THRU-BOLT CLEARANCE - WHEN USING A THRU-BOLT AT ANY MOUNTING LOCATION, BE SURE THAT YOUR HOLE HAS 1/16" CLEARANCE.

ADDITIONAL SHELVING OPTIONS**HD-1632GM**

ITEM NO.	PART NUMBER	DESCRIPTION	QTY.
1	EP1646GML	END PANEL, KD 46 X 16,L	1
2	EP1646GMR	END PANEL, KD 46 X 16, R	1
3	SF21632X-G	SHELF, STD, 2X16X32, GRAY	3
4	SF21232X-G	SHELF, STD, 2X12X32, GRAY	1
5	HDW66983	HARDWARE KIT FOR LOW ROOF 16 INCH SHELVING	1

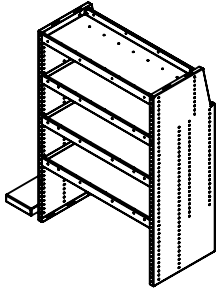
**HD-1640GM**

ITEM NO.	PART NUMBER	DESCRIPTION	QTY.
1	EP1646GML	END PANEL, KD 46 X 16,L	1
2	EP1646GMR	END PANEL, KD 46 X 16, R	1
3	SF21640X-G	SHELF, STD, 2X16X40, GRAY	3
4	SF21240X-G	SHELF, STD, 2X12X40, GRAY	1
5	HDW66983	HARDWARE KIT FOR LOW ROOF 16 INCH SHELVING	1

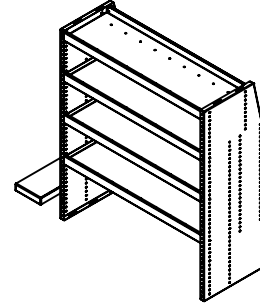
**HD-1644GM**

ITEM NO.	PART NUMBER	DESCRIPTION	QTY.
1	EP1646GML	END PANEL, KD 46 X 16,L	1
2	EP1646GMR	END PANEL, KD 46 X 16, R	1
3	SF21644X-G	SHELF, STD, 2X16X44, GRAY	3
4	SF21244X-G	SHELF, STD, 2X12X44, GRAY	1
5	HDW66983	HARDWARE KIT FOR LOW ROOF 16 INCH SHELVING	1

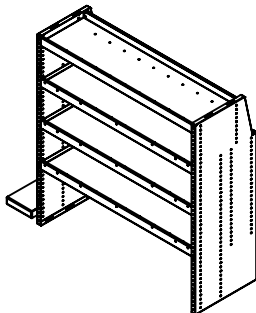
**HD-1650GM**

ITEM NO.	PART NUMBER	DESCRIPTION	QTY.
1	EP1646GML	END PANEL, KD 46 X 16,L	1
2	EP1646GMR	END PANEL, KD 46 X 16, R	1
3	SF21650X-G	SHELF, STD, 2X16X50, GRAY	3
4	SF21250X-G	SHELF, STD, 2X12X50, GRAY	1
5	HDW66983	HARDWARE KIT FOR LOW ROOF 16 INCH SHELVING	1

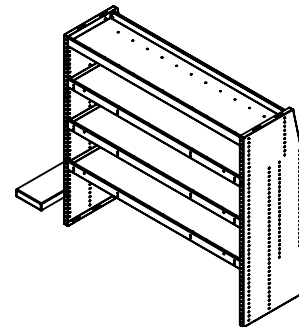
**HD-1660GM**

ITEM NO.	PART NUMBER	DESCRIPTION	QTY.
1	EP1646GML	END PANEL, KD 46 X 16,L	1
2	EP1646GMR	END PANEL, KD 46 X 16, R	1
3	SF21660X-G	SHELF, STD, 2X16X60, GRAY	3
4	SF21260X-G	SHELF, STD, 2X12X60, GRAY	1
5	HDW66983	HARDWARE KIT FOR LOW ROOF 16 INCH SHELVING	1

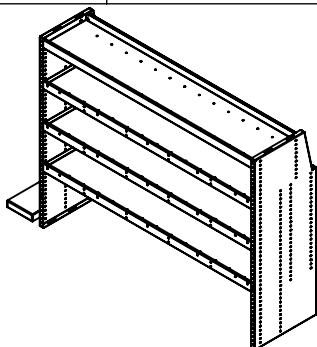
**HD-1632GMC**

ITEM NO.	PART NUMBER	DESCRIPTION	QTY.
1	EP1646GMLC	CONDUIT END PANEL, GM LR, 16X46	1
2	EP1646GMRC	CONDUIT END PANEL, GM LR, 16X46	1
3	SF21632X-G	SHELF, STD, 2X16X32, GRAY	3
4	SF21232X-G	SHELF, STD, 2X12X32, GRAY	1
5	HDW66983	HARDWARE KIT FOR LOW ROOF 16 INCH SHELVING	1

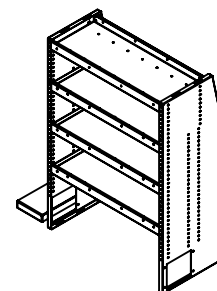

ADDITIONAL SHELVING OPTIONS**HD-1640GMC**

ITEM NO.	PART NUMBER	DESCRIPTION	QTY.
1	EP1646GMLC	CONDUIT END PANEL, GM LR, 16X46	1
2	EP1646GMRC	CONDUIT END PANEL, GM LR, 16X46	1
3	SF21640X-G	SHELF, STD, 2X16X40, GRAY	3
4	SF21240X-G	SHELF, STD, 2X12X40, GRAY	1
5	HDW66983	HARDWARE KIT FOR LOW ROOF 16 INCH SHELVING	1

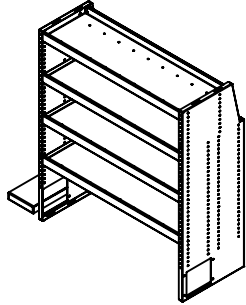
**HD-1644GMC**

ITEM NO.	PART NUMBER	DESCRIPTION	QTY.
1	EP1646GMLC	CONDUIT END PANEL, GM LR, 16X46	1
2	EP1646GMRC	CONDUIT END PANEL, GM LR, 16X46	1
3	SF21644X-G	SHELF, STD, 2X16X44, GRAY	3
4	SF21244X-G	SHELF, STD, 2X12X44, GRAY	1
5	HDW66983	HARDWARE KIT FOR LOW ROOF 16 INCH SHELVING	1

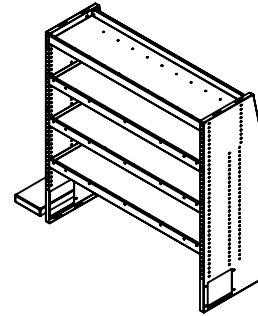
**HD-1650GMC**

ITEM NO.	PART NUMBER	DESCRIPTION	QTY.
1	EP1646GMLC	CONDUIT END PANEL, GM LR, 16X46	1
2	EP1646GMRC	CONDUIT END PANEL, GM LR, 16X46	1
3	SF21650X-G	SHELF, STD, 2X16X50, GRAY	3
4	SF21250X-G	SHELF, STD, 2X12X50, GRAY	1
5	HDW66983	HARDWARE KIT FOR LOW ROOF 16 INCH SHELVING	1

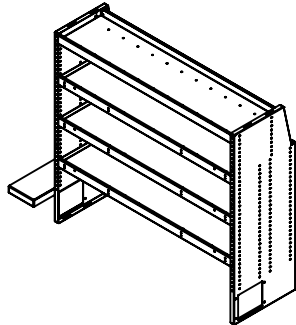
**HD-1660GMC**

ITEM NO.	PART NUMBER	DESCRIPTION	QTY.
1	EP1646GMLC	CONDUIT END PANEL, GM LR, 16X46	1
2	EP1646GMRC	CONDUIT END PANEL, GM LR, 16X46	1
3	SF21660X-G	SHELF, STD, 2X16X60, GRAY	3
4	SF21260X-G	SHELF, STD, 2X12X60, GRAY	1
5	HDW66983	HARDWARE KIT FOR LOW ROOF 16 INCH SHELVING	1

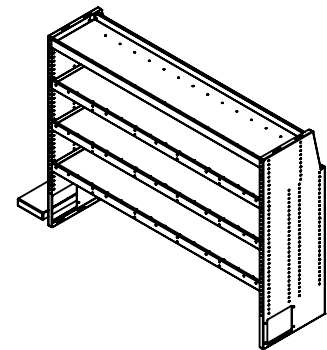
**HD-1632TL**

ITEM NO.	PART NUMBER	DESCRIPTION	QTY.
1	EP1650TLL	END PANEL, FORD LR, 16X50, GRAY	1
2	EP1650TLR	END PANEL, FORD LR, 16X50, GRAY	1
3	SF21632X-G	SHELF, STD, 2X16X32, GRAY	3
4	SF21232X-G	SHELF, STD, 2X12X32, GRAY	1
5	HDW66983	HARDWARE KIT FOR LOW ROOF 16 INCH SHELVING	1

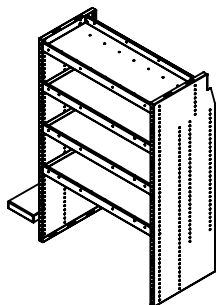
**HD-1640TL**

ITEM NO.	PART NUMBER	DESCRIPTION	QTY.
1	EP1650TLL	END PANEL, FORD LR, 16X50, GRAY	1
2	EP1650TLR	END PANEL, FORD LR, 16X50, GRAY	1
3	SF21640X-G	SHELF, STD, 2X16X40, GRAY	3
4	SF21240X-G	SHELF, STD, 2X12X40, GRAY	1
5	HDW66983	HARDWARE KIT FOR LOW ROOF 16 INCH SHELVING	1

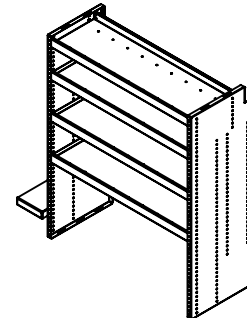

ADDITIONAL SHELVING OPTIONS**HD-1644TL**

ITEM NO.	PART NUMBER	DESCRIPTION	QTY.
1	EP1650TLL	END PANEL, FORD LR, 16X50, GRAY	1
2	EP1650TLR	END PANEL, FORD LR, 16X50, GRAY	1
3	SF21644X-G	SHELF, STD, 2X16X44, GRAY	3
4	SF21244X-G	SHELF, STD, 2X12X44, GRAY	1
5	HDW66983	HARDWARE KIT FOR LOW ROOF 16 INCH SHELVING	1

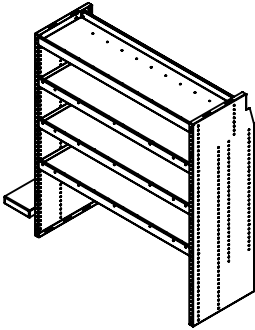
**HD-1650TL**

ITEM NO.	PART NUMBER	DESCRIPTION	QTY.
1	EP1650TLL	END PANEL, FORD LR, 16X50, GRAY	1
2	EP1650TLR	END PANEL, FORD LR, 16X50, GRAY	1
3	SF21650X-G	SHELF, STD, 2X16X50, GRAY	3
4	SF21250X-G	SHELF, STD, 2X12X50, GRAY	1
5	HDW66983	HARDWARE KIT FOR LOW ROOF 16 INCH SHELVING	1

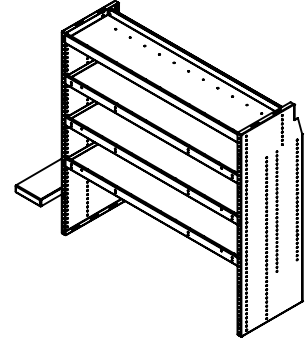
**HD-1660TL**

ITEM NO.	PART NUMBER	DESCRIPTION	QTY.
1	EP1650TLL	END PANEL, FORD LR, 16X50, GRAY	1
2	EP1650TLR	END PANEL, FORD LR, 16X50, GRAY	1
3	SF21660X-G	SHELF, STD, 2X16X60, GRAY	3
4	SF21260X-G	SHELF, STD, 2X12X60, GRAY	1
5	HDW66983	HARDWARE KIT FOR LOW ROOF 16 INCH SHELVING	1

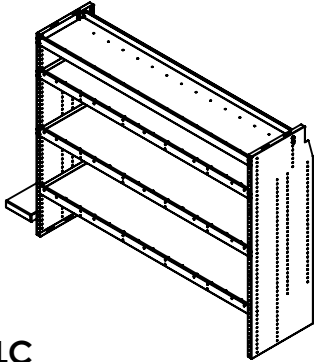
**HD-1632TLC**

ITEM NO.	PART NUMBER	DESCRIPTION	QTY.
1	EP1650TLLC	CONDUIT END PANEL, FORD LR, 16X50, GRAY	1
2	EP1650TLRC	CONDUIT END PANEL, FORD LR, 16X50, GRAY	1
3	SF21632X-G	SHELF, STD, 2X16X32, GRAY	3
4	SF21232X-G	SHELF, STD, 2X12X32, GRAY	1
5	HDW66983	HARDWARE KIT FOR LOW ROOF 16 INCH SHELVING	1

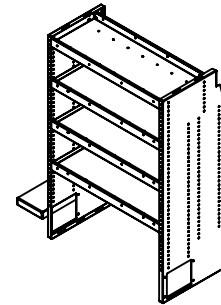
**HD-1640TLC**

ITEM NO.	PART NUMBER	DESCRIPTION	QTY.
1	EP1650TLLC	CONDUIT END PANEL, FORD LR, 16X50, GRAY	1
2	EP1650TLRC	CONDUIT END PANEL, FORD LR, 16X50, GRAY	1
3	SF21640X-G	SHELF, STD, 2X16X40, GRAY	3
4	SF21240X-G	SHELF, STD, 2X12X40, GRAY	1
5	HDW66983	HARDWARE KIT FOR LOW ROOF 16 INCH SHELVING	1

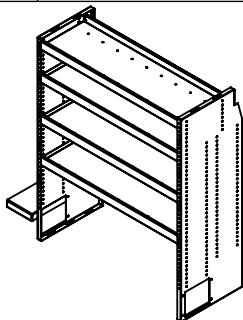
**HD-1644TLC**

ITEM NO.	PART NUMBER	DESCRIPTION	QTY.
1	EP1650TLLC	CONDUIT END PANEL, FORD LR, 16X50, GRAY	1
2	EP1650TLRC	CONDUIT END PANEL, FORD LR, 16X50, GRAY	1
3	SF21644X-G	SHELF, STD, 2X16X44, GRAY	3
4	SF21244X-G	SHELF, STD, 2X12X44, GRAY	1
5	HDW66983	HARDWARE KIT FOR LOW ROOF 16 INCH SHELVING	1

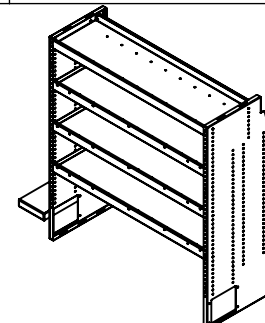

ADDITIONAL SHELVING OPTIONS**HD-1650TLC**

ITEM NO.	PART NUMBER	DESCRIPTION	QTY.
1	EP1650TLLC	CONDUIT END PANEL, FORD LR, 16X50, GRAY	1
2	EP1650TLRC	CONDUIT END PANEL, FORD LR, 16X50, GRAY	1
3	SF21650X-G	SHELF, STD, 2X16X50, GRAY	3
4	SF21250X-G	SHELF, STD, 2X12X50, GRAY	1
5	HDW66983	HARDWARE KIT FOR LOW ROOF 16 INCH SHELVING	1

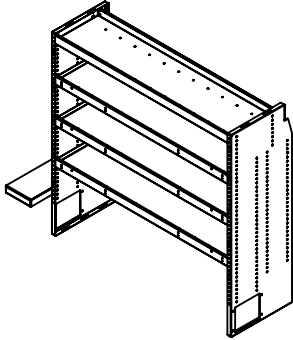
**HD-1660TLC**

ITEM NO.	PART NUMBER	DESCRIPTION	QTY.
1	EP1650TLLC	CONDUIT END PANEL, FORD LR, 16X50, GRAY	1
2	EP1650TLRC	CONDUIT END PANEL, FORD LR, 16X50, GRAY	1
3	SF21660X-G	SHELF, STD, 2X16X60, GRAY	3
4	SF21260X-G	SHELF, STD, 2X12X60, GRAY	1
5	HDW66983	HARDWARE KIT FOR LOW ROOF 16 INCH SHELVING	1

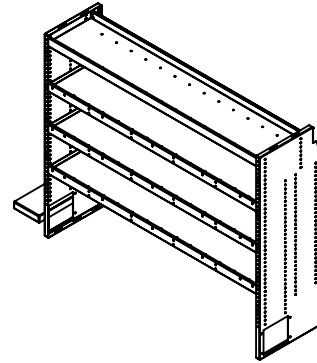

FASTENERS USED

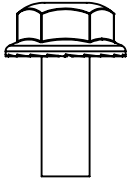

FAS0018
SCREW,HFLNG 1/4-20X.62
QTY: 40

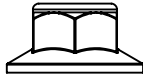

FAS0055
NUT,HEX NLK FLG 1/4-20
QTY: 40

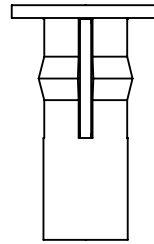

FAS0091
PLUSNUT,5/16-18
QTY: 04

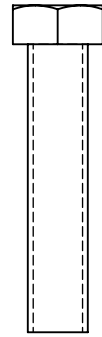

FAS0092
SCREW,HH 5/16-18X1.5
QTY: 04

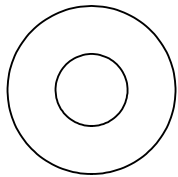

FAS0086
WASHER,FLAT USS 5/16
BAG QTY: 04
RAIL KIT QTY: 02

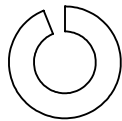

FAS0098
WASHER,LCK SPLIT 5/16
QTY: 04

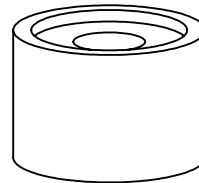

03927-2
SPACER, 11/16"
QTY: 04

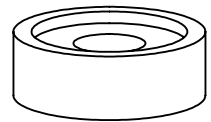

03927-1
PACER, 11/32"
QTY: 04

INCLUDED IN VEHICLE RAIL KIT

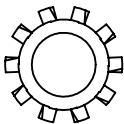

FAS0085
WASHER,LCK EXT 5/16
QTY: 02

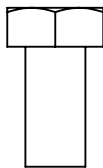

FAS0165
SCREW,HH 5/16-18X.62
QTY: 02



35335-0
SLIDE,1.5"/ AD RAIL
QTY: 02

BEGIN ASSEMBLY

STEP 1 - INSTALL SHELVES WITH GUSSETS

NOTE: THIS IS STANDARD SHELF SPACING. SHELVES MAY BE INSTALLED AT OTHER SPACING DEPENDING ON THE END USER'S NEED.

USE FAS0018 AND FAS0055
(12 PLACES PER SHELF)
7/16 WRENCH
7/16 SOCKET

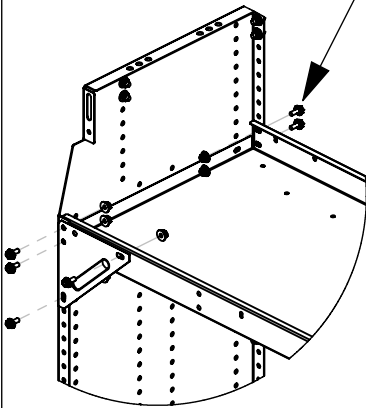

DETAIL A
SCALE 1 : 12

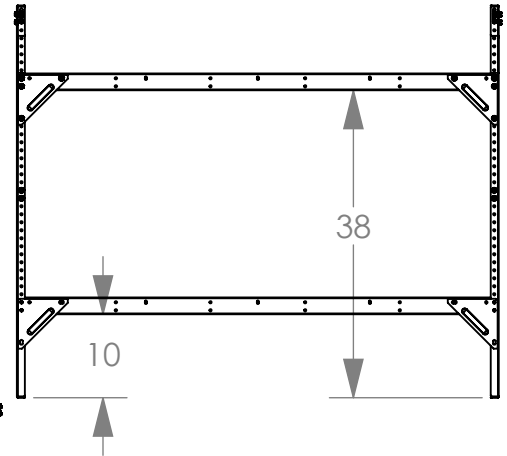
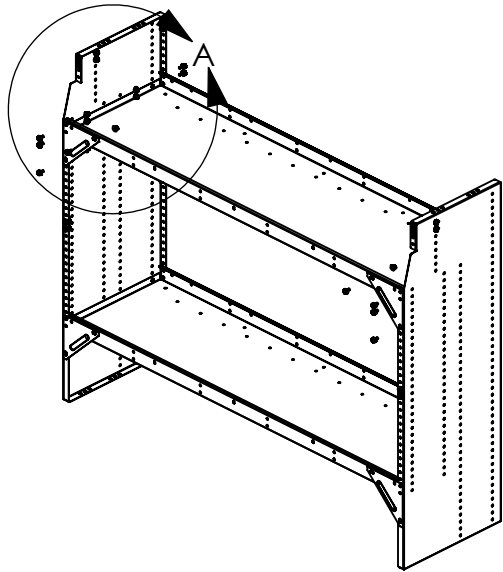

STEP 2 - INSTALL MIDDLE SHELF

USE FAS0018 AND FAS0055
(8 PLACES PER SHELF)
7/16 WRENCH
7/16 SOCKET

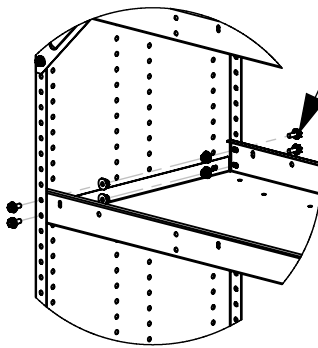

DETAIL B
SCALE 1 : 12

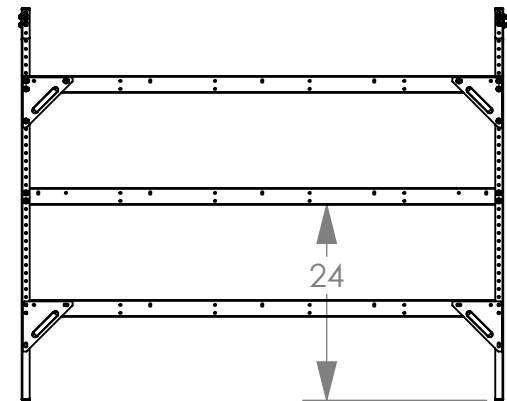
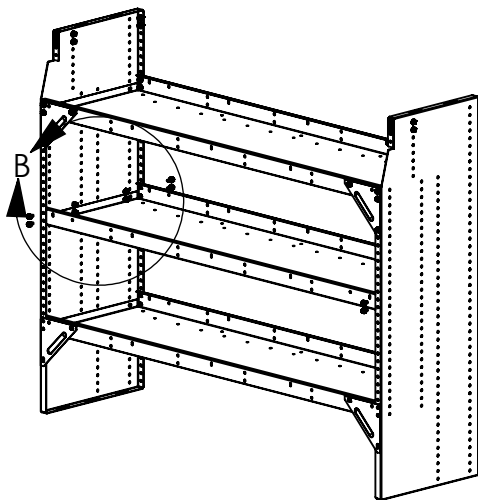

STEP 3 - INSTALL TOP SHELF

USE FAS0018 AND FAS0055
(8 PLACES)
7/16 WRENCH
7/16 SOCKET

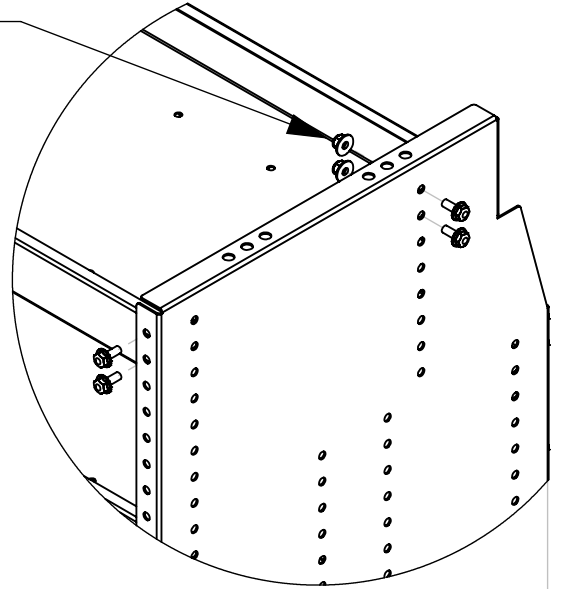
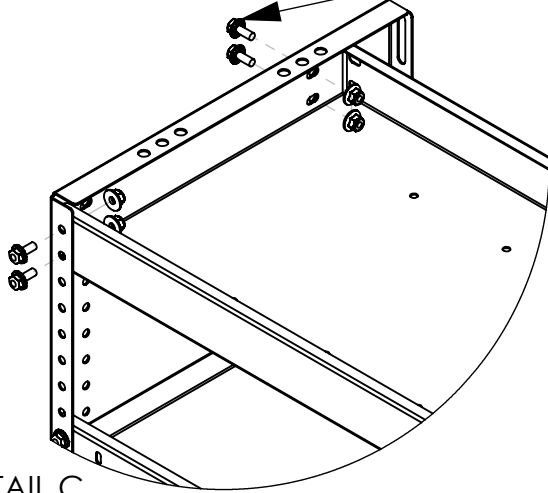

DETAIL C
SCALE 1 : 6

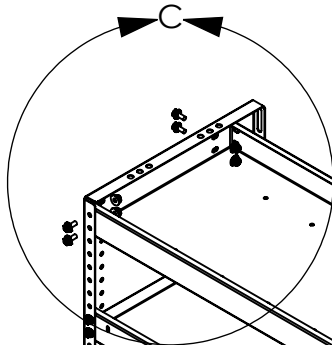

DETAIL D
SCALE 1 : 6

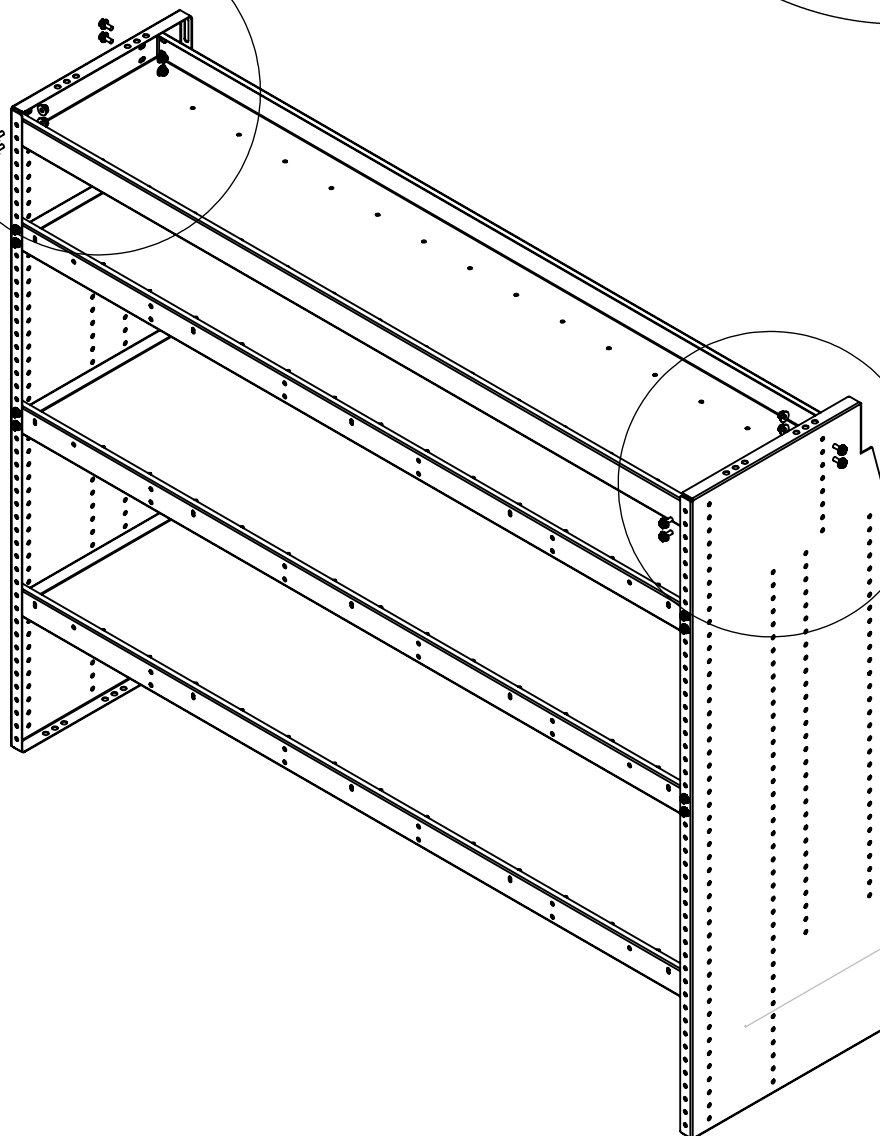
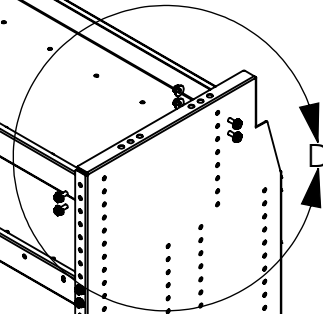

STEP 04 - INSTALL PLUSNUTS FOR FASTENING THE END PANEL BOTTOM AND MOUNT SHELF TO THE VAN

USE FAS0091, FAS0086,
FAS0098, AND FAS0092
(04 PLACES)
1/2 WRENCH
1/2 SOCKET

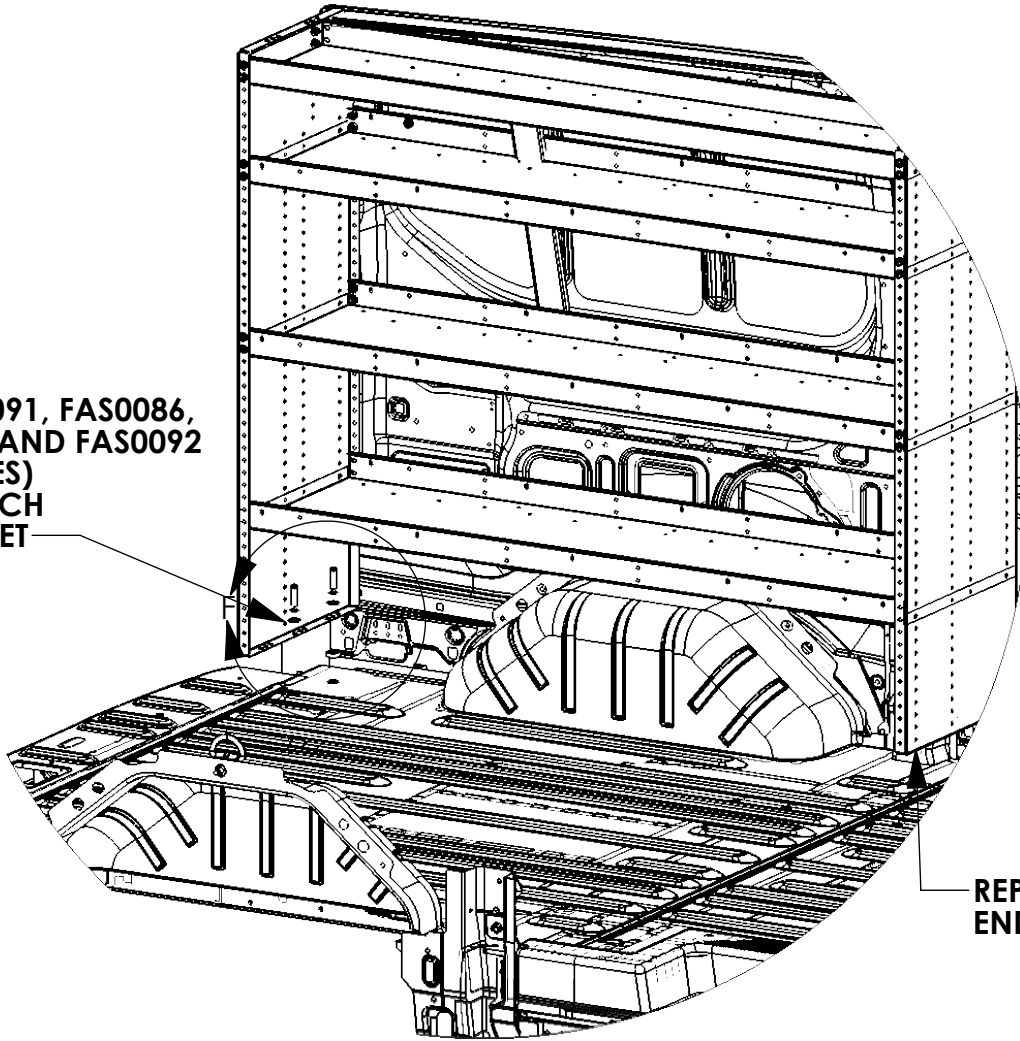

REPEAT ON OTHER
END PANEL

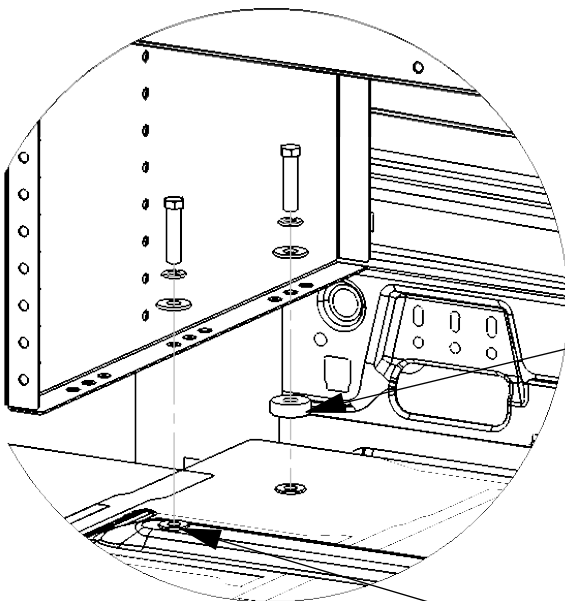

USE THE APPROPRIATE SPACER TO
LEVEL THE SHELVING

FASTEN TO FLOOR RIBS WHERE POSSIBLE

STEP 05 - MOUNT THE TOP OF THE END PANEL TO THE AD RAIL.

**NOTE:
TOP SHELF HIDDEN
FOR VISIBILITY**

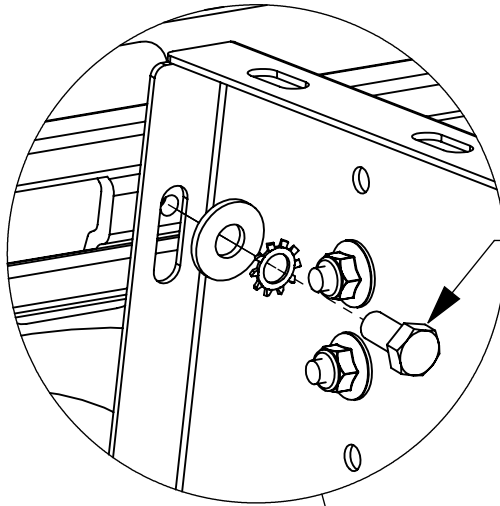

**USE FAS0165, FAS0086,
FAS0085, AND 35335-0
(02 PLACES)
1/2 WRENCH OR 1/2 SOCKET**

**REPEAT ON OTHER
END PANEL**

