



ADRIAN STEEL®

Cargo Management Solutions for Commercial Vehicles

Assembly/Installation Instructions and Owners Manual

ITEM NO.	PART NUMBER	DESCRIPTION	QTY.
1	62617-B	FT SIDE STEP FRONT BRACKET ASSY	1
2	62618-B	FT SIDE STEP MID BRACKET ASSY	1
3	62619-B	FT SIDE STEP REAR BRACKET	1
4	62620-B	SIDE STEP TOP	1

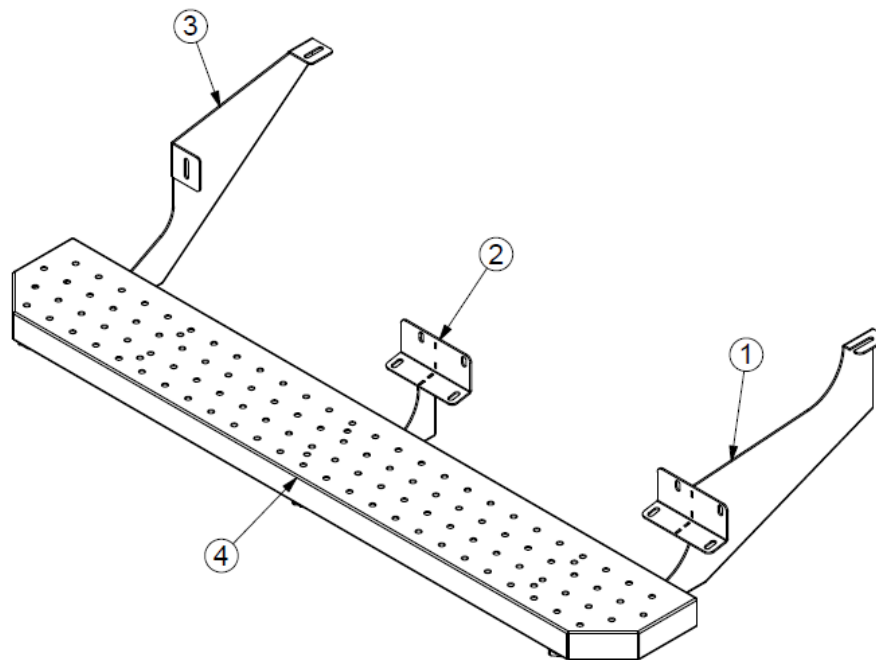

STEPFTSD STEP, SIDE, FORD TRANSIT

- PRECAUTIONS -





 **CAUTION** 
**THE USE AIR IMPACT TOOLS CAN
OVER-TORQUE FASTENERS AND
CAUSE FASTENER FAILURE!**



 **CAUTION** 
**ALL INSTALLATION HOLES SHOULD BE SEALED
WITH SILICON OR BUTYL SEALANT TO PREVENT
EXHAUST FUMES FROM ENTERING THE VEHICLE!**



 **DANGER** 
**INSPECT FOR FUEL TANK, FUEL LINES, BRAKE LINES, HIGH
VOLTAGE BATTERIES AND ELECTRICAL LINES PRIOR TO
DRILLING TO AVOID DAMAGING CRITICAL VEHICLE SYSTEMS
OR INJURY TO INSTALLER DURING INSTALLATION PROCESS!**



 **CAUTION** 
**TO AVOID DAMAGING THE VEHICLE ALWAYS
USE DRILL STOPS WHEN DRILLING ANY IN-
STALLATION HOLES!**



- IMPORTANT WARRANTY REQUIREMENTS -

1. SUBSTITUTING ADRIAN STEEL SPECIFIED FASTENERS FOR ASSEMBLY AND/OR INSTALLATION WILL VOID YOUR PRODUCT WARRANTY.
2. ALL HOLES DRILLED INTO VEHICLE SHOULD HAVE THE RAW METAL EDGES SEALED WITH A SELF-ETCHING PRIMER TO RESIST CORROSION AND POTENTIAL FASTENER POINT FAILURE.
3. ALL FASTENERS USED IN THE INSTALLATION OF THIS PRODUCT SHOULD BE TIGHTENED TO THE TORQUE(S) SPECIFIED IN THESE INSTRUCTIONS.
4. THESE INSTRUCTIONS SHOULD BE KEPT WITH THE VEHICLE.

THE BASIC TOOLS NEEDED FOR MOST INSTALLATIONS



DRILL



DRILL BIT WITH
STOP



RATCHET, SOCKETS
AND/OR WRENCHES



SCREWDRIVERS



MEASURING TAPE

ADDITIONAL TOOLS MAY BE NEEDED FOR THIS INSTALLATION AND THEY WILL BE IDENTIFIED IN THE STEPS THAT FOLLOW.

**Installation and/or Assembly Fasteners
BAGSTEPPTS**

ITEM NO.	PART NUMBER	DESCRIPTION	
1	BAG0507-A	5" x 7" 3MIL AUTOBAG	1
2	FAS0438	SCREW,HFLNG 5/16-18X.75 ZP	6
3	FAS0440	NUT,HEX NLK FLG 5/16-18 - ZP	6
4	FAS0092	Screw, Hex Hd, 5/16-18x1.50 Zn Plate, G8	3
5	FAS0086	WASHER,FLAT USS 5/16 ZP	7
6	FAS0098	Washer, Lock, Split, 5/16, Zinc Plate	3
7	62652	RETAINER BAR, 5/16/-18 X 2-3/8	3
8	FAS0317	NUT,HEX NLK M8-1.25 SS	4
9	FAS0449	SCREW,HFLG 5/16-8X18TC ZP	4

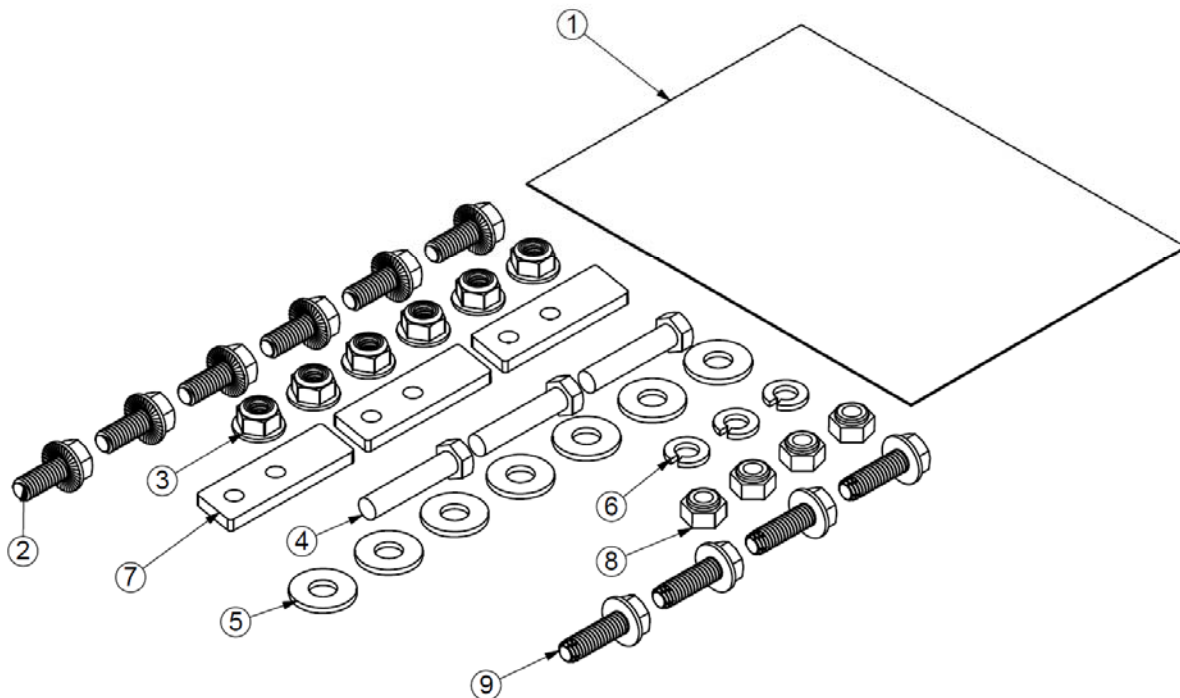

Instructions for Step 01

BRACKET OREINTATION

VIEW FROM TOP SIDE OUTSIDE CURBSIDE DOOR

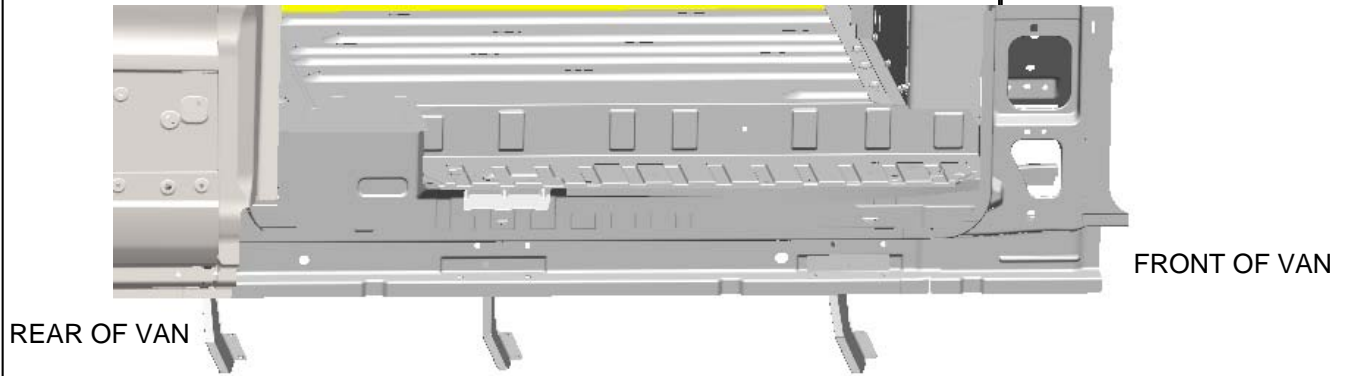

INSTALLING BRACKETS

VIEW FROM BOTTOM SIDE UNDER VAN

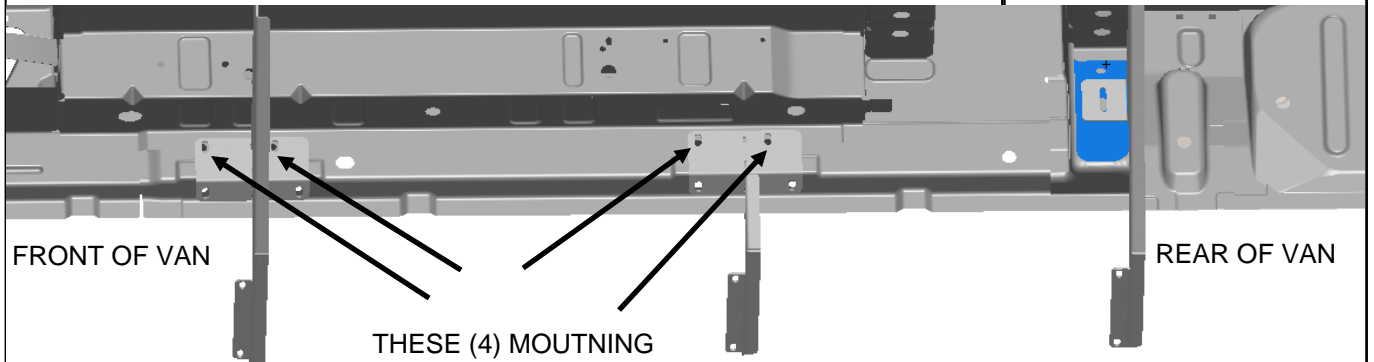

THESE (4) MOUTNING LOCATIONS WILL HAVE OEM STUDS. INSTALL BRACKETS TO THESE LOCATIONS USING WASHERS AND M8 NUTS SHOWN BELOW



ONE PER LOCATION
(4) TOTAL



ONE PER LOCATION
(4) TOTAL

Instructions for Step 02

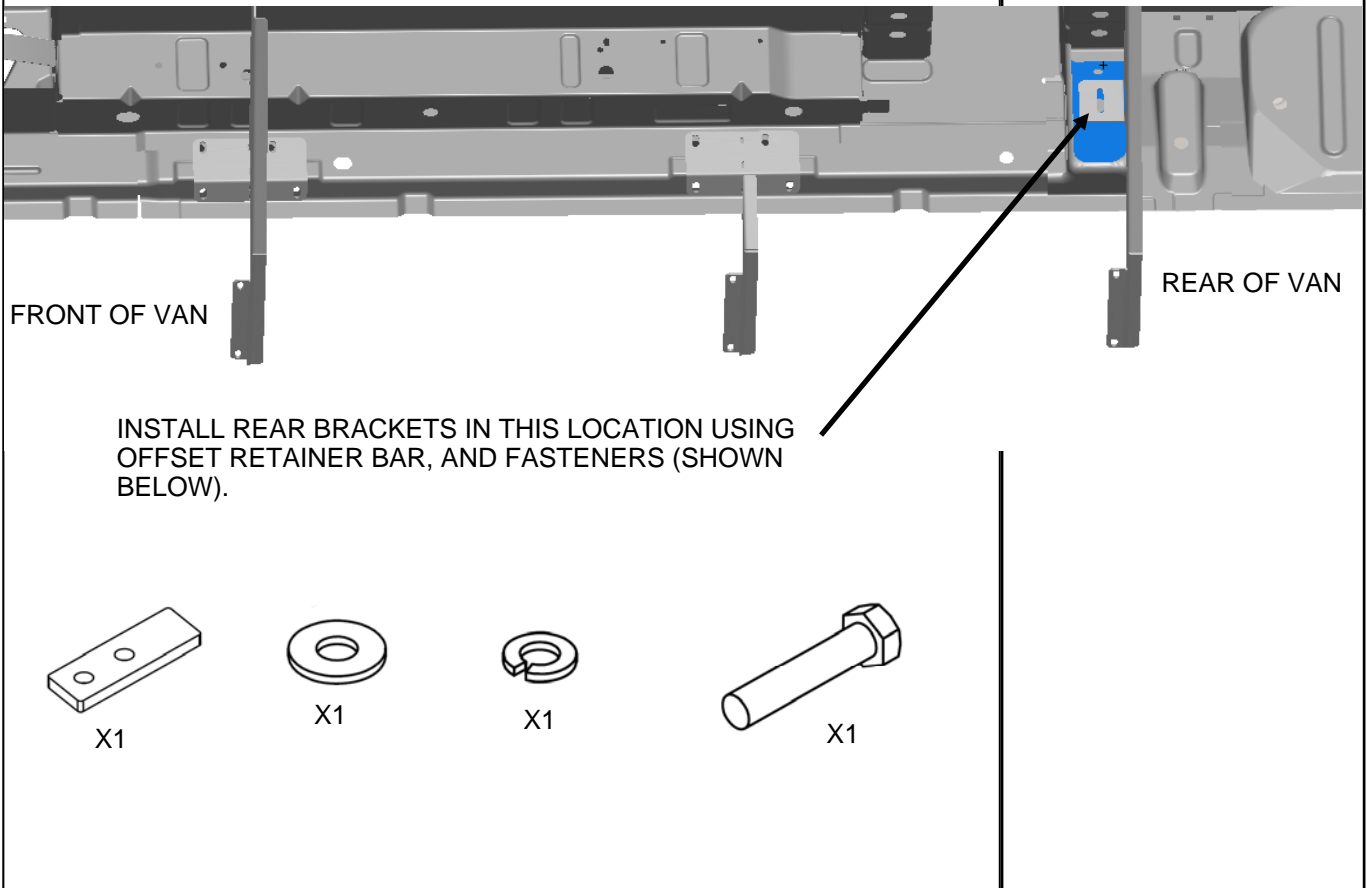
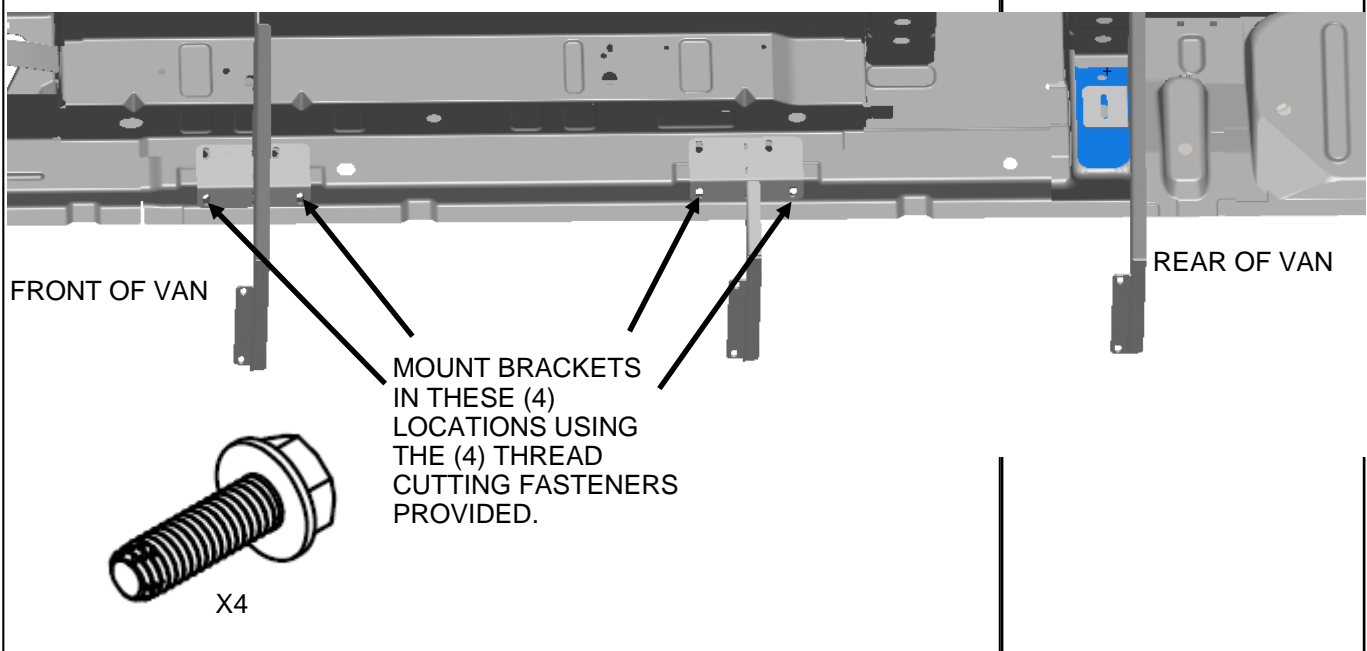

Instructions for Step 03

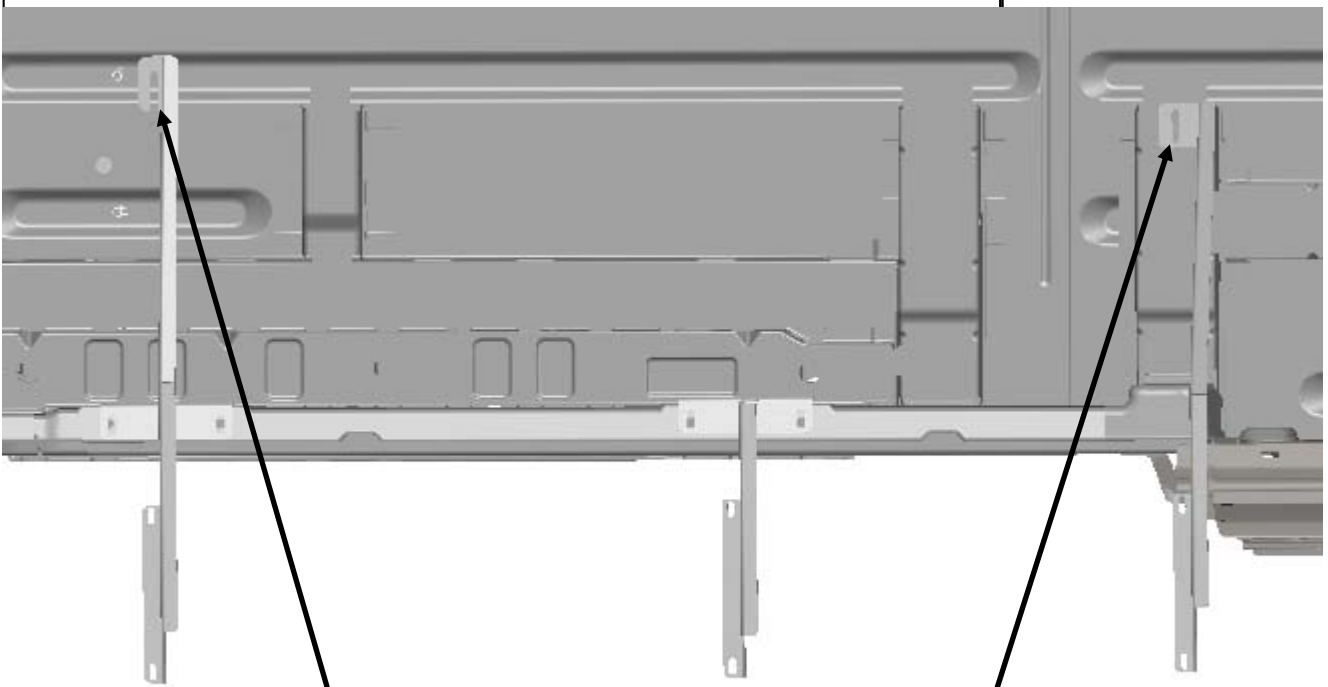

THESE TOP (2) MOUNTING POINTS WILL LINE UP WITH LARGE OEM HOLES IN THE BOTTOM STRUCTURE OF THE VAN. USING THE FASTENERS CALLED OUT BELOW PLEASE MOUNT OUTSIDE BRACKETS TO THESE HOLES.

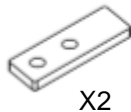

X2



X2



X2

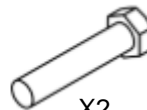

X2

Instructions for Step 04

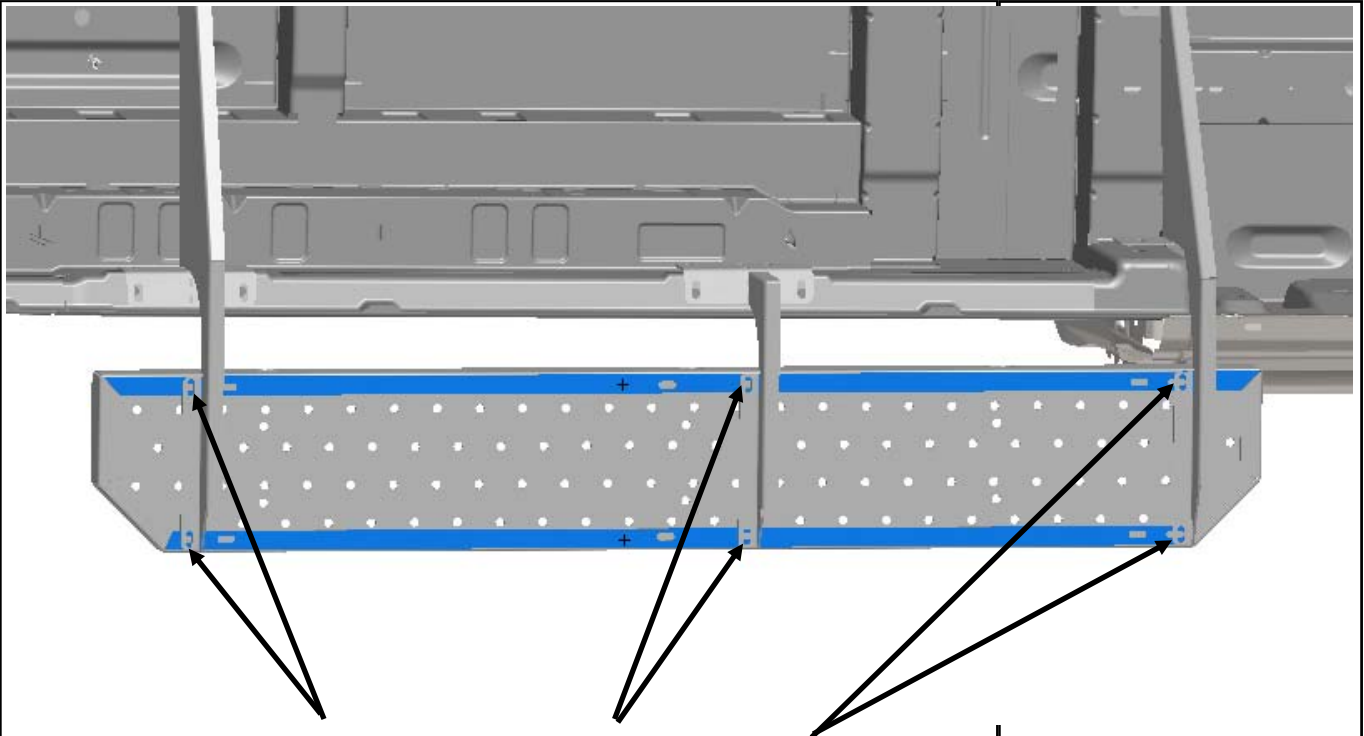

USING THE (6) HOLES SHOW ABOVE, MOUNT THE STEP TO THE BRACKETS. EACH OF THESE HOLES ARE SLOTTED ALLOWING YOU TO ADJUST THE STEP SO IT IS SQUARE TO THE VEHICLE. PLEASE USE FASTENERS CALLED OUT BELOW.



X6



X6