

Introduction / Comments:

This step is made to mount to the Ram Promaster under the Curb Side Sliding door. It mounts using OEM holes that have plusnuts set in them. Please note that this installation differs slightly depending on the wheelbase of the vehicle.

Note:

It is advised that all fasteners used in this assembly and installation should be checked for tightness at the following intervals: @ 2-weeks and again @ 6-weeks of operation. This preventive maintenance step must be completed to ensure your Product gives you long service life.

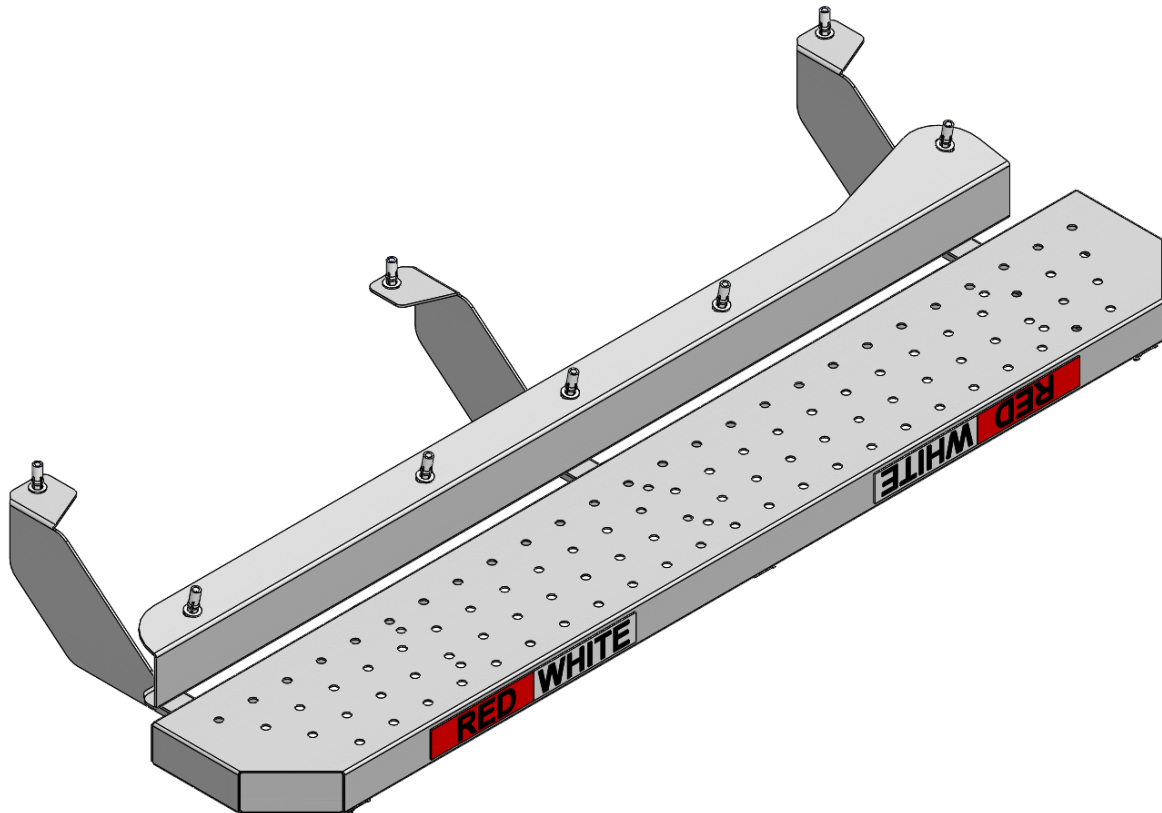

**STEPPMSD
STEP, SIDE, PROMASTER**

- PRECAUTIONS -



CAUTION
THE USE OF AIR IMPACT TOOLS CAN
OVER-TORQUE FASTENERS AND
CAUSE FASTENER FAILURE!



CAUTION
ALL INSTALLATION HOLES SHOULD BE SEALED
WITH SILICON OR BUTYL SEALANT TO PREVENT
EXHAUST FUMES FROM ENTERING THE VEHICLE!



DANGER
INSPECT FOR FUEL TANK, FUEL LINES, BRAKE LINES, HIGH
VOLTAGE BATTERIES AND ELECTRICAL LINES PRIOR TO
DRILLING TO AVOID DAMAGING CRITICAL VEHICLE SYSTEMS
OR INJURY TO INSTALLER DURING INSTALLATION PROCESS!

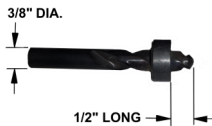

CAUTION
TO AVOID DAMAGING THE VEHICLE ALWAYS USE DRILL
STOPS WHEN DRILLING ANY INSTALLATION HOLES!
ADRIAN AVAILABLE PART #'S 31119-0 (3/8" X 1/2"
DEEP), 31121-0 (1/2" X 1/2" DEEP)



- IMPORTANT WARRANTY REQUIREMENTS -

1. SUBSTITUTING ADRIAN STEEL SPECIFIED FASTENERS FOR ASSEMBLY AND/OR INSTALLATION WILL VOID YOUR PRODUCT WARRANTY.
2. ALL HOLES DRILLED INTO VEHICLE SHOULD HAVE THE RAW METAL EDGES SEALED WITH A SELF-ETCHING PRIMER TO RESIST CORROSION AND POTENTIAL FASTENER POINT FAILURE.
3. ALL FASTENERS USED IN THE INSTALLATION OF THIS PRODUCT SHOULD BE TIGHTENED TO THE TORQUE(S) SPECIFIED IN THESE INSTRUCTIONS.
4. THESE INSTRUCTIONS SHOULD BE KEPT WITH THE VEHICLE.

THE BASIC TOOLS NEEDED FOR MOST INSTALLATIONS



DRILL

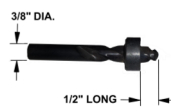

DRILL BIT WITH
STOP

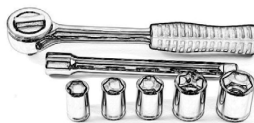

RATCHET, SOCKETS
AND/OR WRENCHES



SCREWDRIVERS



MEASURING TAPE

ADDITIONAL TOOLS MAY BE NEEDED FOR THIS INSTALLATION AND THEY WILL BE IDENTIFIED IN THE STEPS THAT FOLLOW.

If your vehicle contains carpet or a rubber floor mat you will need to prepare the mounting location. Position the product to be installed into the vehicle and once you are satisfied with the mounting locations, mark the mounting locations. Using a 1-3/16" diameter carpet cutter (P/N: 31183-0). Select the appropriate floor spacers as shown in the illustration. Set those aside for use later into the installation process. Using the correct drill bit size for the selected plusnut, drill the mounting holes in the vehicle sheet metal to prepare for installing the plusnuts. If you are thru-bolting at any of the locations simply drill a hole that is 1/16" larger than the bolt size(s) for those locations. Once you have drilled the holes into the vehicle, the raw metal edges should be sealed using a self-etching primer to resist corrosion and potential fastener point failure.

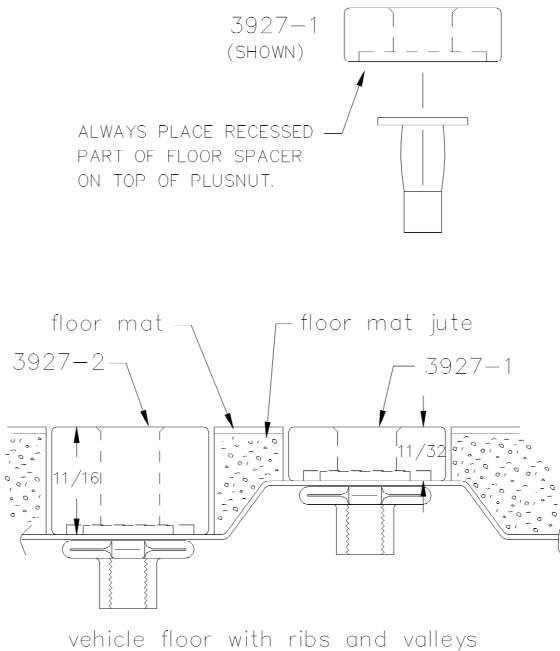

A PLUSNUT (RIVNUT) SETTING TOOL IS REQUIRED FOR PLUSNUT (RIVNUT) INSTALLATION . PLUS NUT SETTING TOOL CAN BE ORDERED THROUGH ADRIAN STEEL, OR USE AN AIR POWERED PLUSNUT SETTING GUN.

1/4-20UNC Plusnut (FAS0052) Use 3/8" dia. drill w/stop
 FAS0080 SCREW, HXHD, 1/4-20UNCx2.00", G8
 FAS0067 WASHER, FLAT, 1/4"ID
 22200-0 PLUSNUT TOOL

5/16-18UNC Plusnut (FAS0091) Use 1/2" dia. drill w/stop
 FAS0095 SCREW, HXHD, 5/16-18UNCx2.00", G8
 FAS0086 WASHER, FLAT, 5/16"ID
 22200-0 PLUSNUT TOOL

Place barrel of the plusnut body in sheet metal thru hole until flange is flush with sheet metal.
 Using a 9/16" combination wrench of plusnut tool body and a second hand wrench, ratchet, or air tool, rotate the hex bolt head CW to draw plus nut flanges up (set the plusnut).

**Installation and/or Assembly Fasteners
BAGSTEPPMS**

ITEM NO.	PART NUMBER	DESCRIPTION	QTY.
1	BAG0406-A	4" x 6" 3MIL AUTOBAG	1
2	FAS0438	SCREW,HFLNG 5/16-18X.75 ZP	9
3	FAS0440	NUT,HEX NLK FLG 5/16-18 - ZP	9
4	FAS0098	Washer, Lock, Split, 5/16, Zinc Plate	8
5	FAS0086	WASHER,FLAT USS 5/16 ZP	8
6	FAS0092	Screw, Hex Hd, 5/16-18x1.50 Zn Plate, G8	8
7	FAS0091	Plusnut, 5/16	8

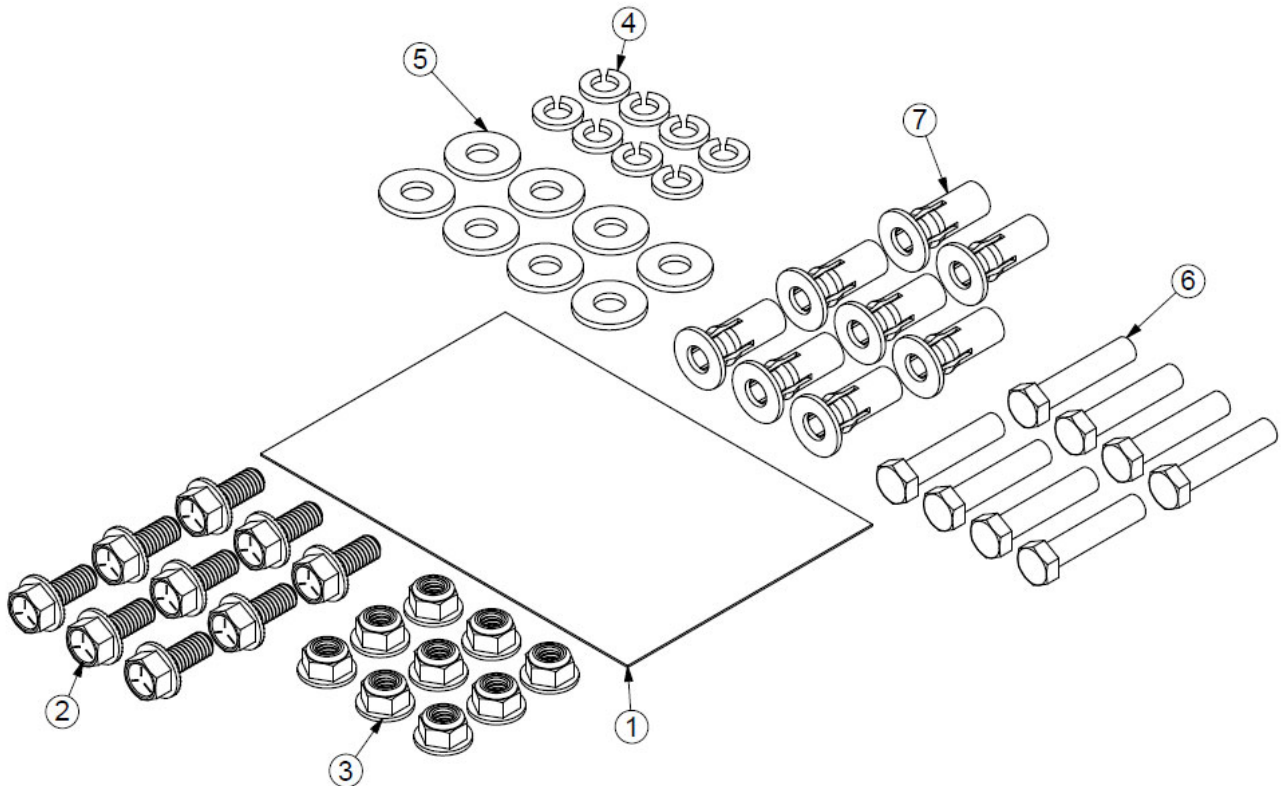

Step 01A (For 136" Wheelbase)

Hold the C-Channel to the frame under the side door. Use it to locate the holes below. Set plus nuts in the holes, and fasten loosely as shown. Do not fully tighten yet.

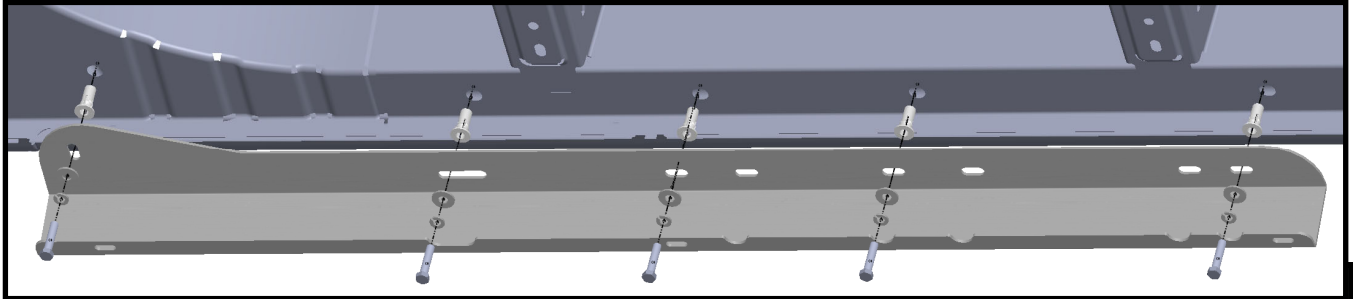

FAS0091 (5)
PLUSNUT, 5/16-18

FAS0086 (5)
WASHER, FLAT 5/16

FAS0098 (5)
WASHER, LCK SPLIT 5/16

FAS0092 (5)
SCREW, HH 5/16-18X1.5

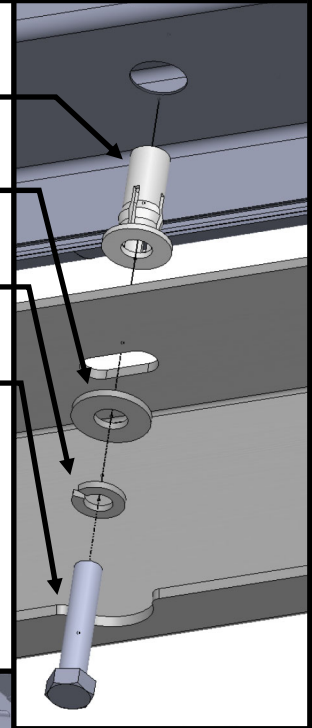

Step 02A (For 136" wheelbase)

Use the arms to locate the next set of holes by lining up the rear most slot with the C-channel and holding the arm perpendicular to the C-channel. Set plus nuts in the holes, and fasten loosely as shown. Do not fully tighten yet. The fasteners below are the same as in Step 01.

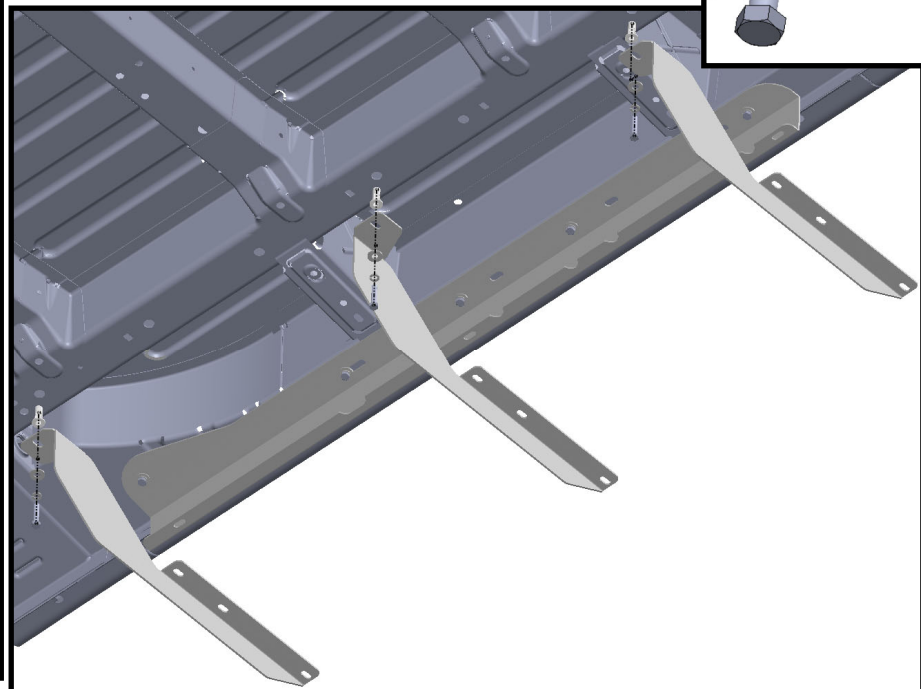
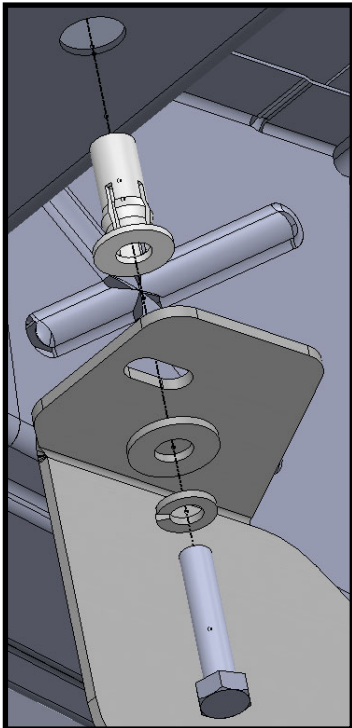

Step 01B (For 159" Wheelbase) Hold the C-Channel to the frame under the side door. Use it to locate the holes shown below. Set plus nuts in the holes, and fasten loosely as shown. Do not fully tighten yet.

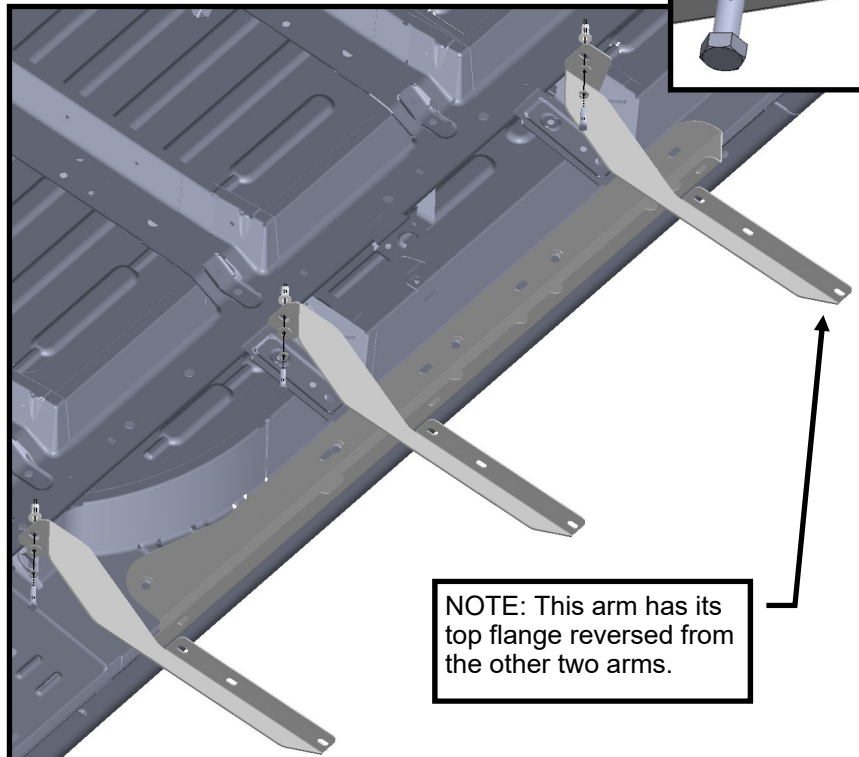
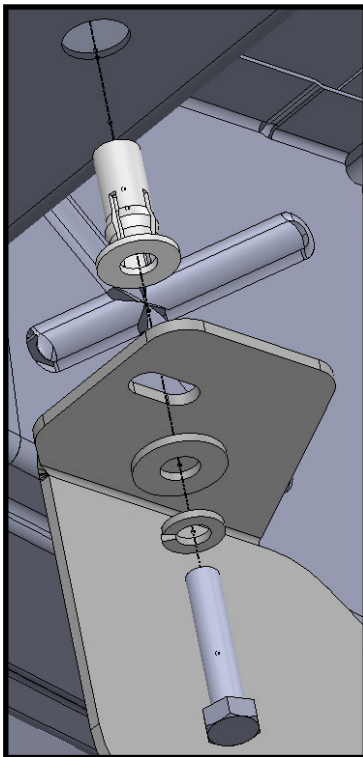
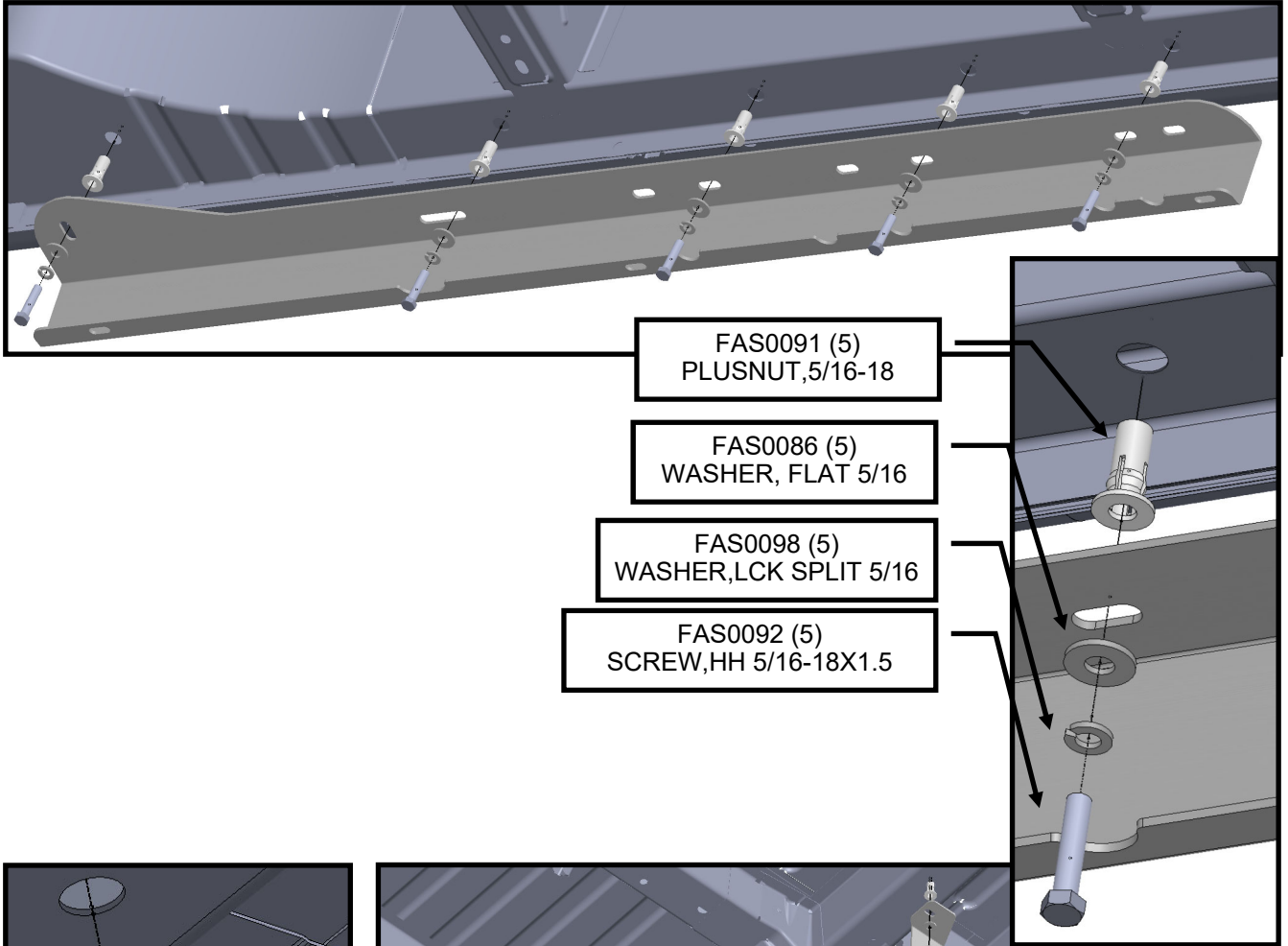

Step 03 Fasten the arms to the C-Channel loosely as shown. Do not fully tighten yet.

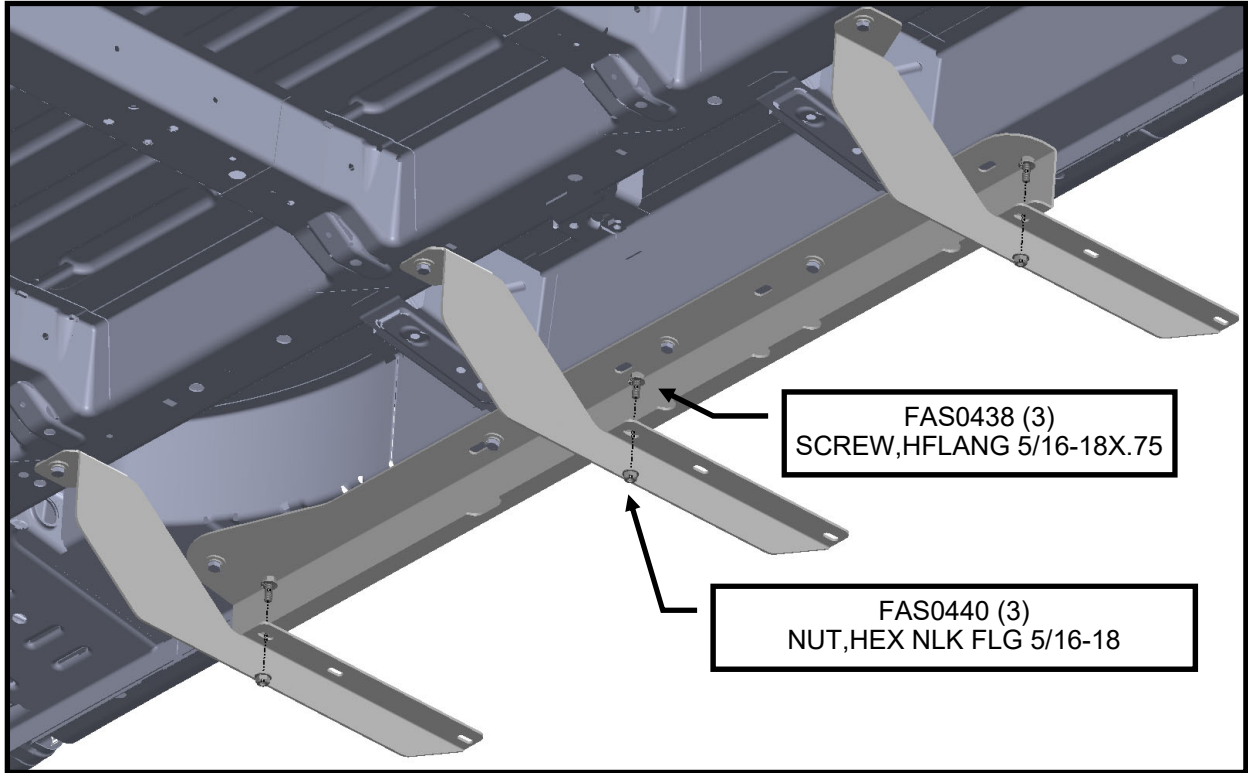

Step 04 Fasten the step body to the arms. The step has two sets of slots, but only one set will align with the arms. Make sure the step is parallel with the side of the van and fully tighten.

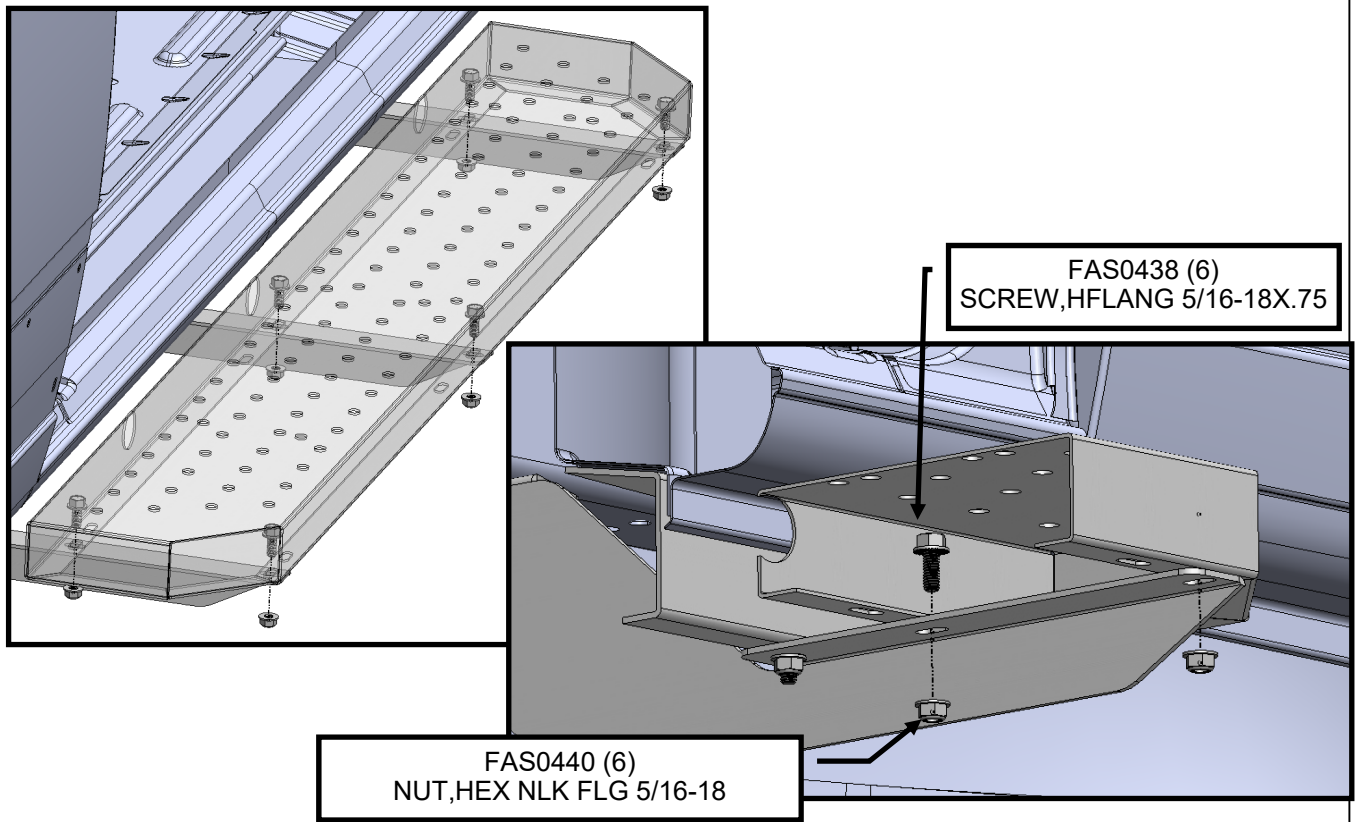

Step 05 Fully tighten all the fasteners. The install is now complete.

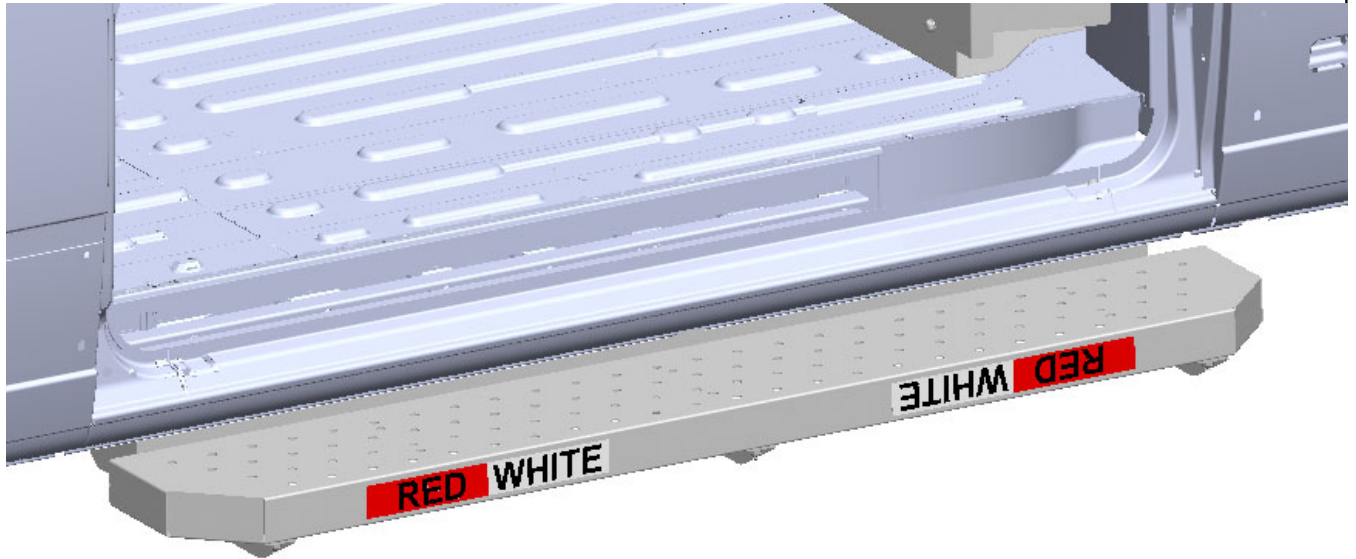

**DOUBLE CHECK ALL FASTENERS LOCATIONS TO BE SURE THAT ALL
FASTENERS ARE TIGHTENED TO SPECIFICATIONS.
YOUR INSTALLATION IS NOW COMPLETE!
STOW THIS COPY IN THE VEHICLE FOR FUTURE REFERENCES!**