

# INSTALLATION GUIDE

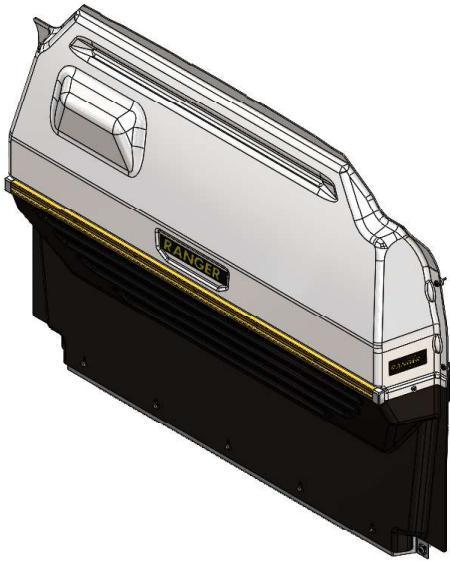

**3320-FTL**



**3310-FTL**

## CONTOURED PARTITION

Transit Partition Low Roof



For digital install guide, visit:  
<https://rangerdesign.com/products/ford-transit-lr-contoured-van-partition-composite-3310-ftl/>



# WARNING

“Before the installation, carefully read the supplied installation guide to avoid possible injuries and damages resulting from incorrect installation. Always keep the installation guide in an accessible location at all times for reference during installation.

Installers must always wear appropriate safety gear during installation. This may include but is not limited to gloves, steel toed shoes, and safety glasses.

Drilling is required to complete this install. Before drilling, ensure that you will not hit any critical parts of the vehicle like the gas tank, wiring harness, or hose. Consult OEM vehicle or documentation as necessary. When drilling, use a drill collar to reduce risk of damage to the vehicle.

This installation guide provides general installation instructions and best practices. However, various vehicles and product install locations may require additional steps. It is the installers responsibility to ensure the install is safe and secure. For further questions please contact us at 1-800-565-5321.”

## Phase 1 - Assembly

<input type="checkbox"/> 1.1 Setup.....	3 - 5
<input type="checkbox"/> 1.2 Partition Assembly.....	6 - 8

## Phase 2 - Installation

<input type="checkbox"/> 2.1 Tips On How To Attach a Plusnut.....	9
<input type="checkbox"/> 2.2 Vehicle Preparation.....	10 -11
<input type="checkbox"/> 2.3 Contoured Partition Installation.....	12 - 17

# REQUIRED ITEMS

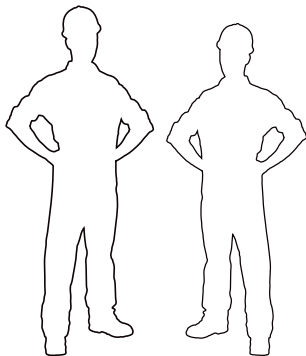

2  
PERSONS

- Cordless Impact
- Cordless Drill
- Marker
- Plusnut Tool
- Tape Measure
- 3/8" Drill Bit
- 7/16" Socket
- 1/2" Socket
- 1" Hole Saw
- 10mm Socket
- 13mm Socket

# PHASE 1 – ASSEMBLY

## 1.1 SETUP

1.1.1 Unpack components; compare with the bill of materials.

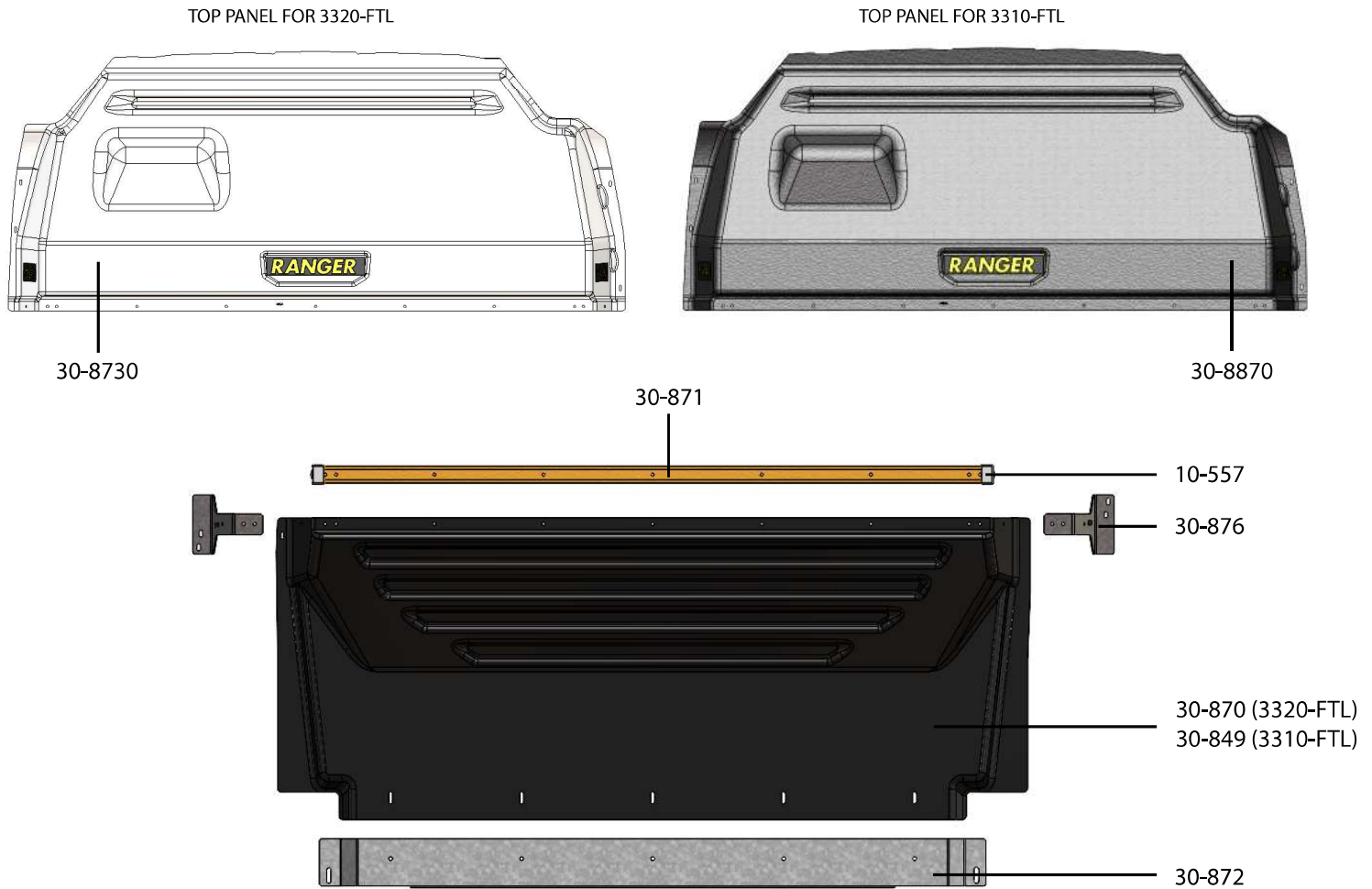

1.1.2 Verify all parts are present.

### BILL OF MATERIALS

Item No.	Description	Qty.
10-557	Mounting Track End Cap	2
30-870 or 30-849	Lower Panel	1
30-871	Mounting Track	1
30-872	Floor Bracket	1
30-876	Side Bracket	2
79-932	Warning Label Bilingual	1
30-8730 or 30-8870	Upper Panel	1
94-3046	Assembly Fastener Bag	1
96-3031	Installation Fastener Bag	1

1.1.3 Identify the 94-3046 and 96-3031 fastener bags.

94-3046 Fastener Bag

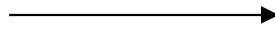



Hardware Assembly

11x  # 90-114 Hex Bolt  
1/4"-20 x 1"  
GR-5 ZINC

5x  # 90-204 Hex Bolt  
5/16"-18 x 3/4"  
GR-5 ZINC



11x  # 94-112 Serrated Nut  
5/16"-20  
ZINC

5x  # 94-116 Serrated Nut  
5/16"-18  
ZINC



5x  # 98-116 Flat Washer  
5/16", 7/8" OD  
ZINC

11x  # 98-112 Flat Washer  
1/4", 3/4" OD  
ZINC

11x

	#90-114 Hex Bolt 1/4" x 1"
	#98-112 Flat Washer
	#94-112 Serrated Nut







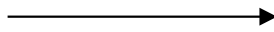

5x

	#90-204 Hex Bolt 5/16" x 3/4"
	#98-116 Flat Washer
	#94-116 Serrated Nut

96-3031 Fastener Bag









Hardware Assembly

- 3x  # 90-130 Hex Bolt  
1/4"-20 x 2"  
GR-5 ZINC
- 2x  # 90-836 Hex Bolt  
M6-1.00 x 40 CL 12.9 DIN  
933 BLACK OXIDE
- 2x  # 90-010 #90-010 Screw, Torx 7/16" x 1"
- 3x  # 94-130 Plusnut .250
- 5x  # 98-112 Flat Washer  
1/4", 3/4" OD  
ZINC
- 5x  # 98-118 Lock Washer  
Regular 1/4"  
ZINC
- 10x  # 98-157 Spacer  
0.375" ID, x 1.0" OD x 0.25" LONG  
NYLON
- 5x  # 98-158 Retaining Washer  
M16 ( 1/4")  
NYLON
- 2x  # 98-141 #98-141 Square Flat Washer





2x

 #90-010 Screw, Torx 7/16" x 1"  
 #98-141 Square Flat Washer

3x

 #90-130 Hex Bolt 1/4" x 2"  
 #98-118 Lock Washer  
 #98-112 Flat Washer  
 #98-157 Spacers ( 2 )  
 #98-158 Retaining Washer  
 #94-130 Plusnut .250

2x

 #90-836 Hex Bolt M6 x 40  
 #98-118 Lock Washer  
 #98-112 Flat Washer  
 #98-157 Spacers ( 2 )  
 #98-158 Retaining Washer

1.2.1 Attach the end caps on the both ends of the mounting track.

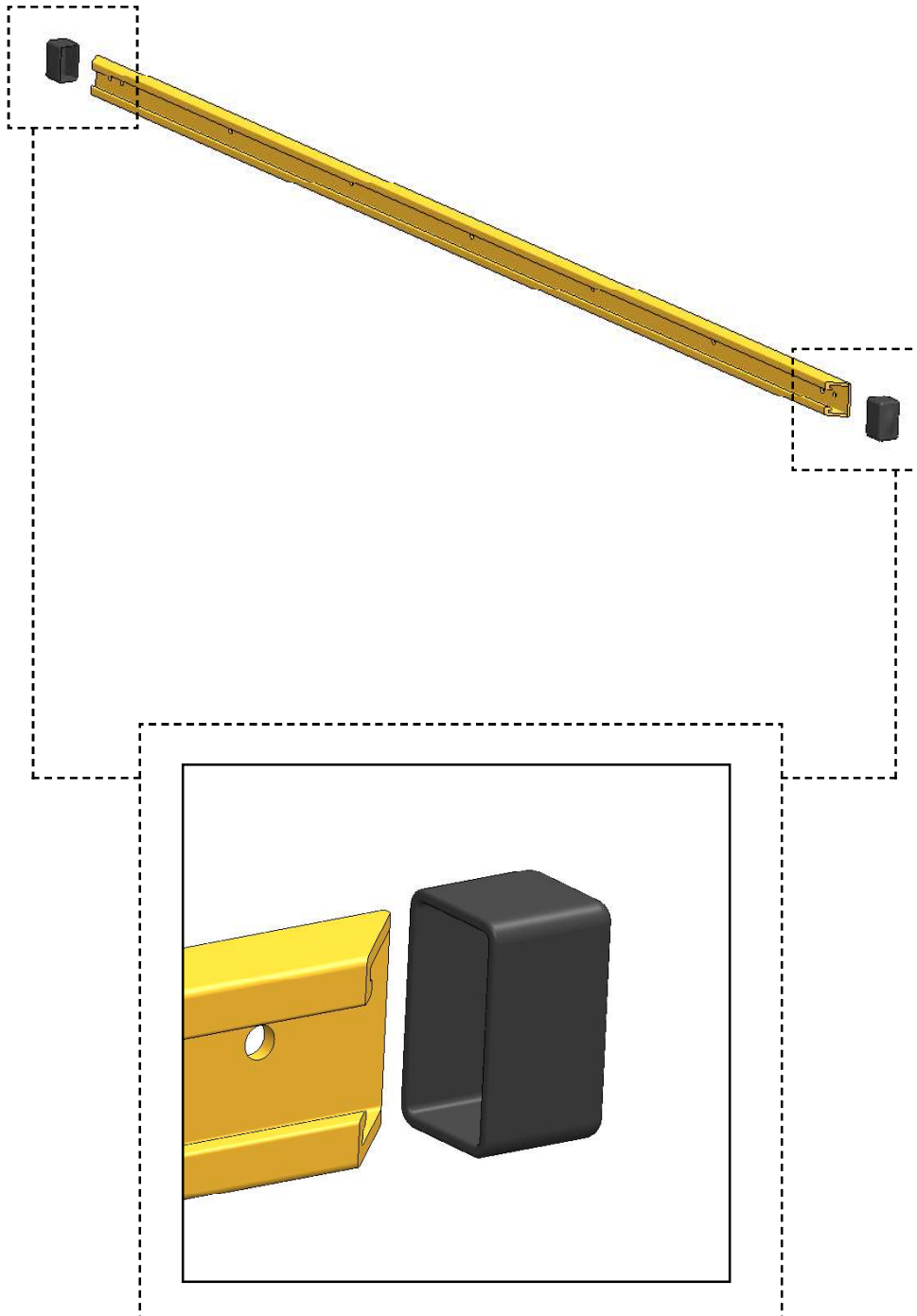

1.2.2 Attach the lower panel and mounting track to the upper panel.

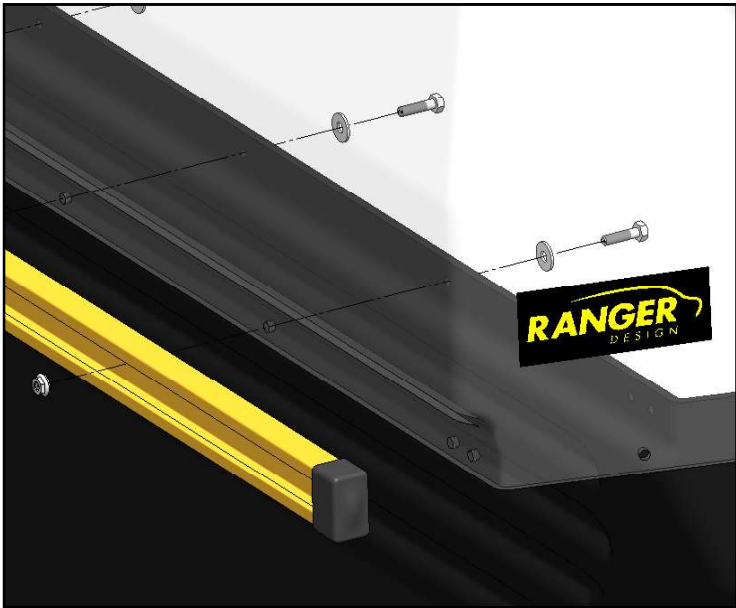
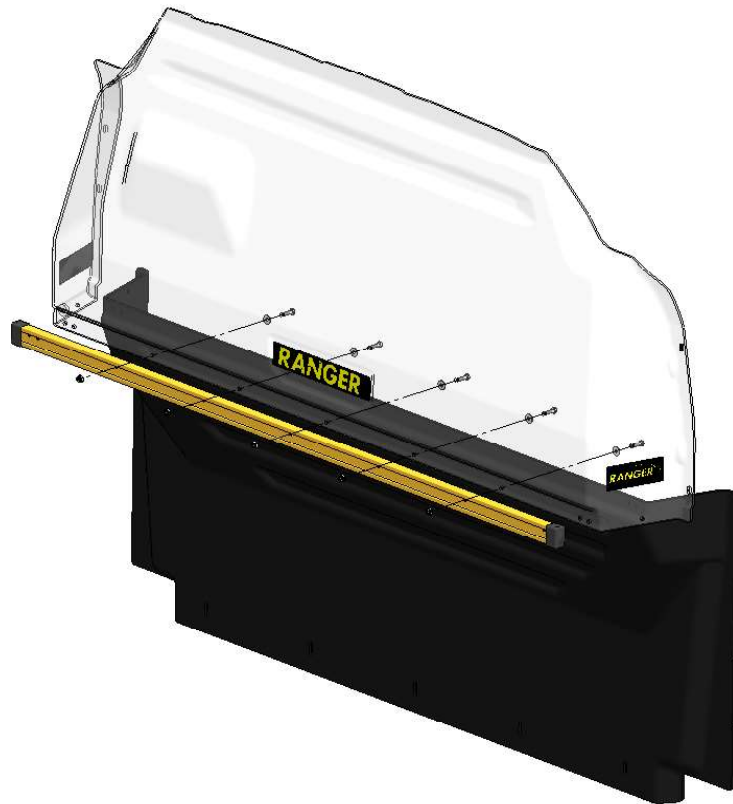



**TOOLS**

- ❑ Cordless Impact
- ❑ 7/16" Socket

**HARDWARE USED**

5x

	#90-114 Hex Bolt 1/4" x 1"
	#98-112 Flat Washer
	#94-112 Serrated Nut

1.2.3 Attach the side brackets to the panels and track.

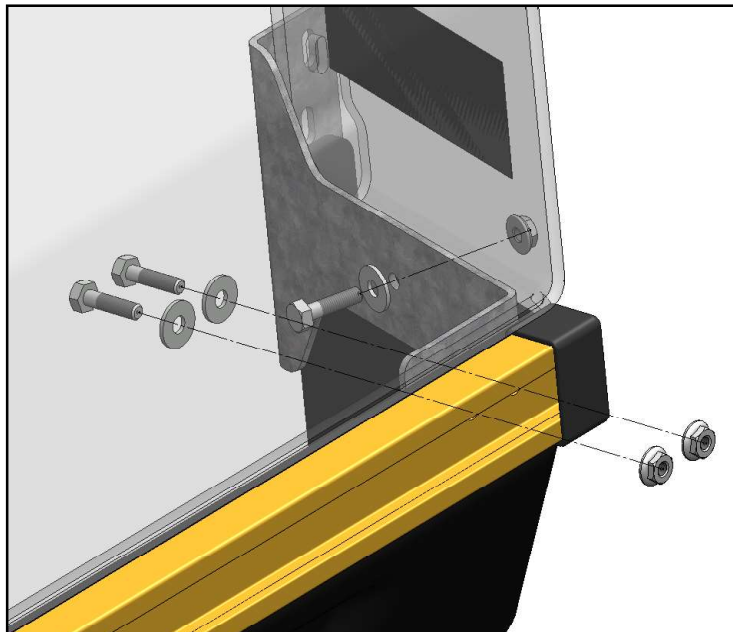
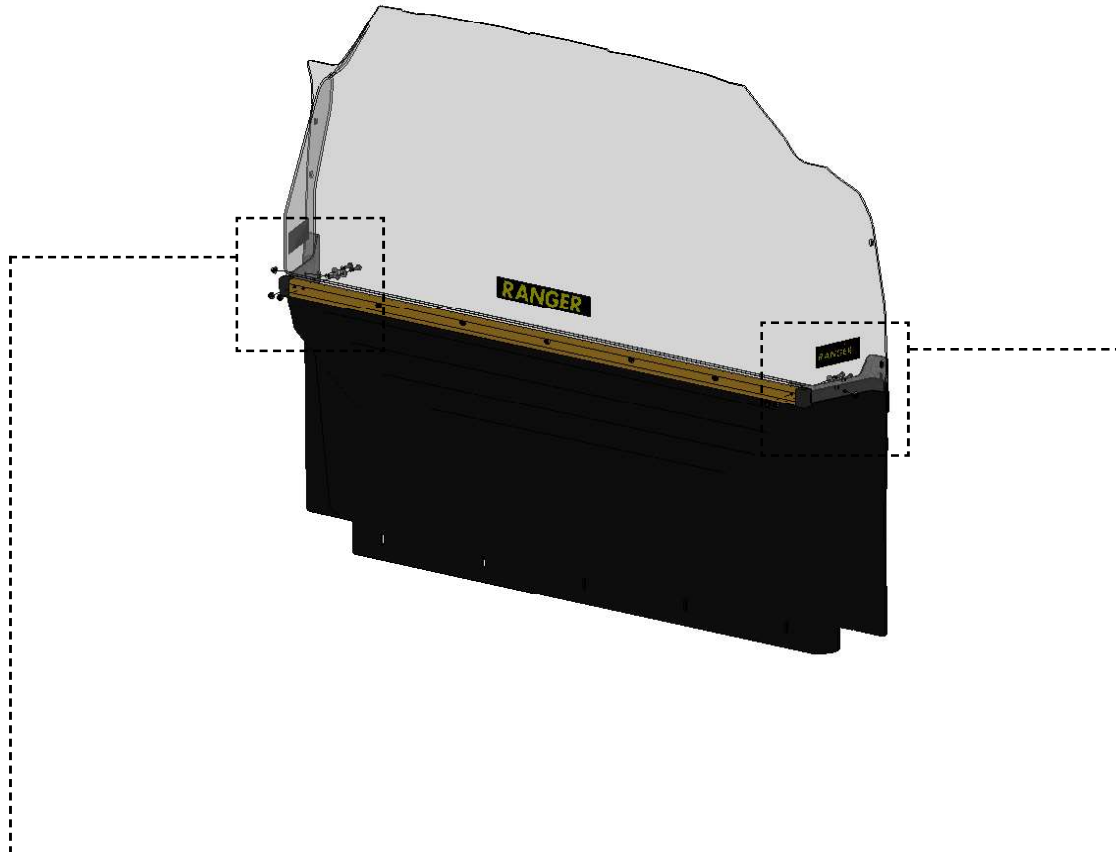

TOOLS

- Cordless Impact
- 7/16" Socket

HARDWARE USED

6X



#90-114 Hex Bolt 1/4" x 1"



#98-112 Flat Washer



#94-112 Serrated Nut



# PHASE 2 – INSTALLATION

## 2.1 TIPS ON HOW TO ATTACH A PLUSNUT

2.1.1 Attach the plusnut using the plusnut gun.

TIPS: Put the plusnut on the plusnut gun, then attach the plusnut in the hole by turning the gun forward until the plusnut locks, then remove the gun by turning in reverse.

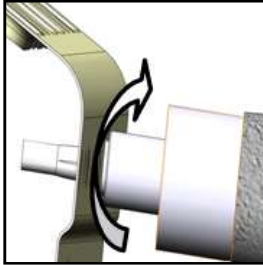

FORWARD

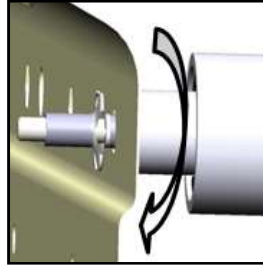

REVERSE



2.1.2 Attach the plusnut using the 6490 plusnut tool.

NOTE: The hardware used for the 6490 plusnut tool is not included in the fastener bag.  
The 6490 plusnut tool can be ordered separately upon demand at no charge.



6490

### HARDWARE USED

-  Flat washer 1/4"
-  Flat washer 1/4" BS x 3/4" OD

### TOOLS

- Cordless Impact
- 7/16" Socket
- 9/16" Wrench

TIPS STEP 1:  
Assemble the 6490 plusnut tool with the hardware needed, plusnut and the 9/16" wrench as shown.



TIPS STEP 2:

Attach the plusnut in the hole by turning the bolt forward using an impact with a 7/16" socket until the plusnut locks, then remove the bolt by turning the impact in reverse.



FORWARD



REVERSE

2.2.1 Driver and passenger sides preparation.

NOTE: This partition is design w/ floor make a new holes in the van if the holes is not align in the holes of the panels.

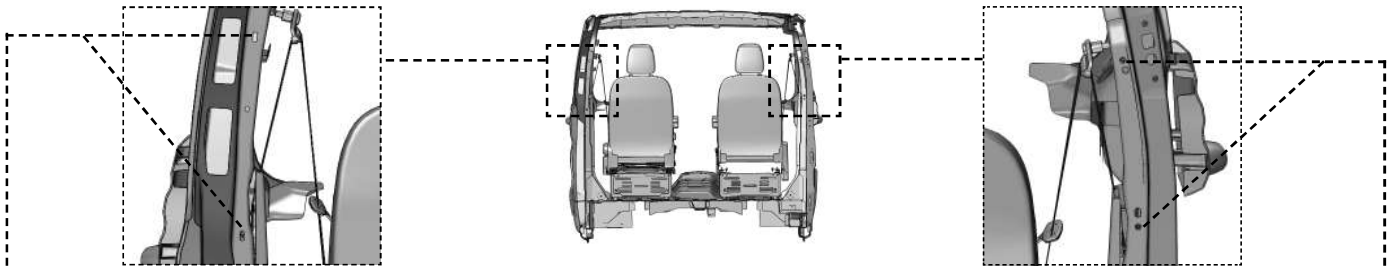

Put a mark on the plastic over these 2 holes.



- TOOLS
- Marker

Remove the factory handle in the van.



- TOOLS
- Flat Screwdriver
  - Cordless Impact
  - 10mm Socket

Use 1" hole saw to drill through the plastic cover over these two factory holes.



- TOOLS
- 1" Hole Saw
  - Cordless Drill

After removing the handle, pull the rubber out, then remove the bracket by removing the two bolts.

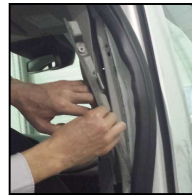

- TOOLS
- Cordless Impact
  - 10mm Socket

Use 3/8" drill to enlarge the bottom part of these two factory holes.



- TOOLS
- Drill Collar Set at 1/2"
  - Cordless Drill
  - 3/8" Drill Bit

Put a mark on the plastic over the 2 threaded holes.

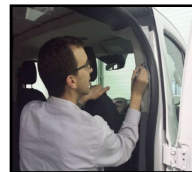

- TOOLS
- Marker

Attach plusnuts on the two factory holes.



- TOOLS
- Plusnut Tool

HARDWARE USED  
2x

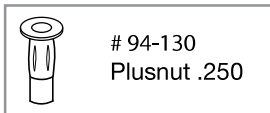

Gently pull the plastic b-pillar from the metal. Use a 1" hole saw to drill through the plastic cover over these two factory threaded holes. (Use caution not to damage the threaded holes).

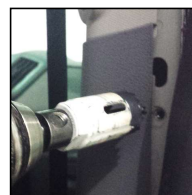

- TOOLS
- 1" Hole Saw
  - Cordless Drill

2.2.2 Driver and passenger side preparation.

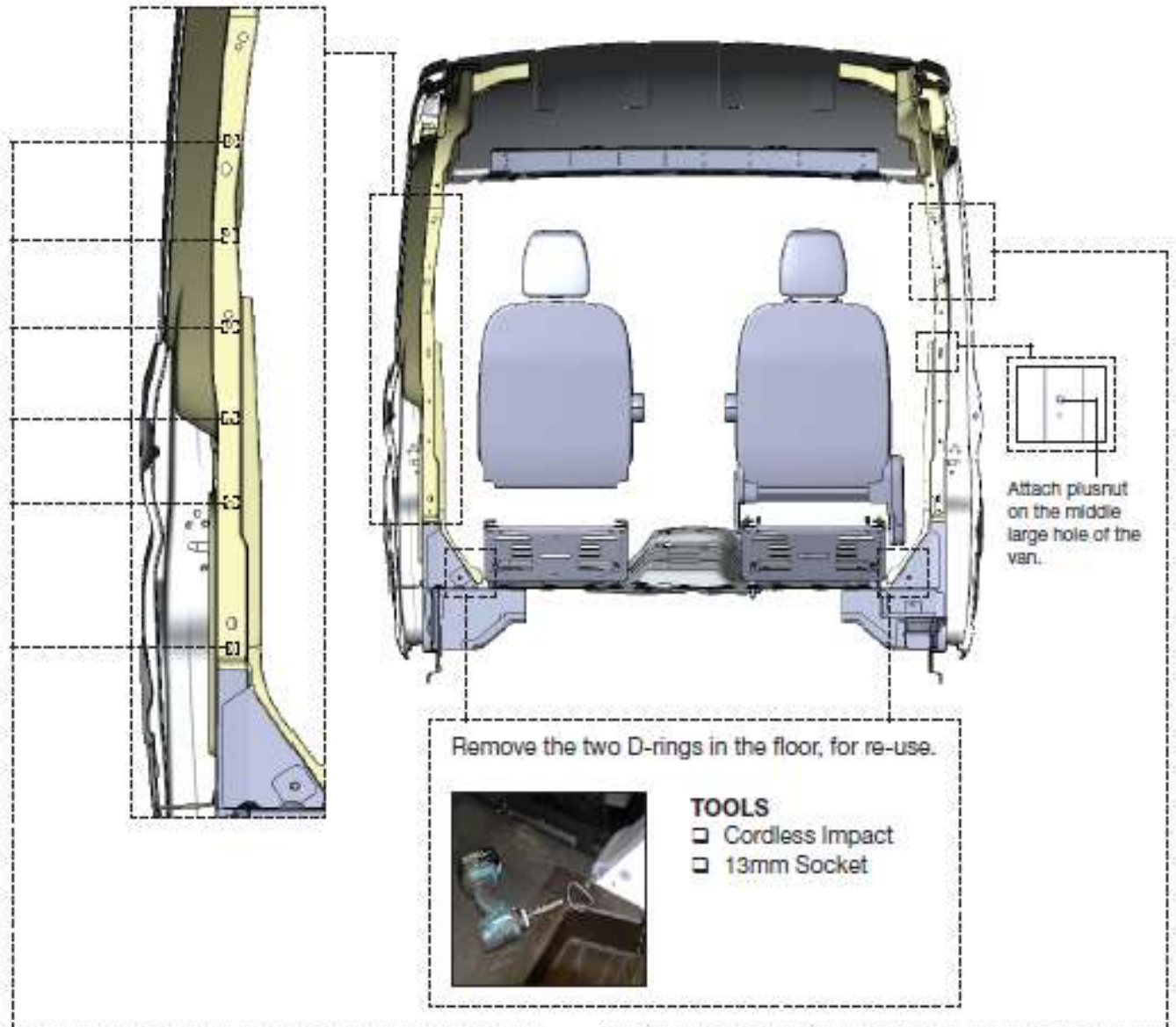

Attach plusnuts on the five factory holes.



**TOOLS**

- ☐ Plusnut Tool

**HARDWARE USED**

**6x**



# 94-130  
Plusnut .250

Remove the factory handle in the van.



**TOOLS**

- ☐ Cordless Impact
- ☐ 10mm Socket

2.3.4 Attach the upper panel to the passenger side of the van.

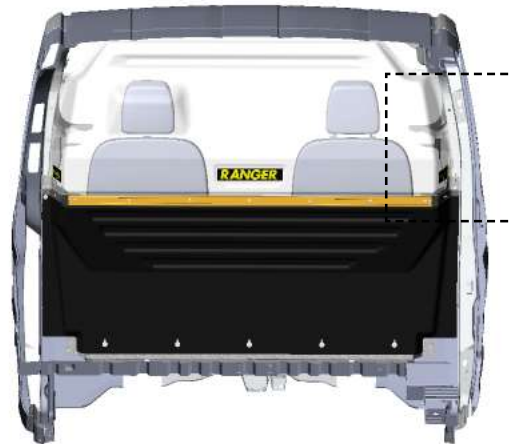

Put a bolt, lock washer, flat washer, 2 spacers and a retaining washer in the 1st and 2nd holes of the passenger side of the upper panel.

HARDWARE USED

2×



#90-836 Hex Bolt M6 × 40

#98-118 Lock Washer

#98-112 Flat Washer

#98-157 Spacers ( 2 )

#98-158 Retaining washer



Attach the upper panel to the passenger side threaded holes of the vehicle.

NOTE: Hand-tighten the bolts just to hold the upper panel for adjustment.

TOOLS

- Cordless Impact
- 10mm Socket

2.3.5 Attach the upper panel to the driver side of the van.

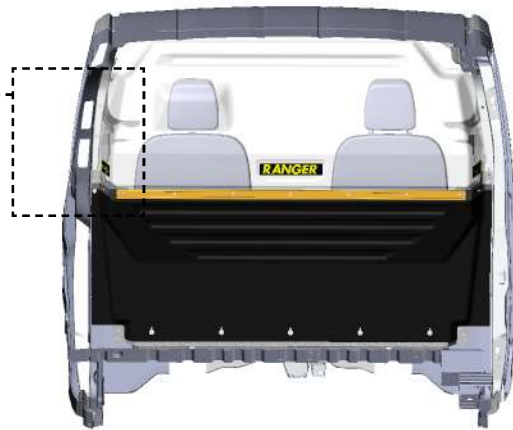

Put a bolt, lock washer, flat washer, 2 spacers and a retaining washer in the 3 holes of the driver side of the upper panel.

HARDWARE USED

2x

-  #90-130 Hex Bolt 1/4" x 2"
-  #98-118 Lock Washer
-  #98-112 Flat Washer
-  #98-157 Spacers ( 2 )
-  #98-158 Retaining Washer

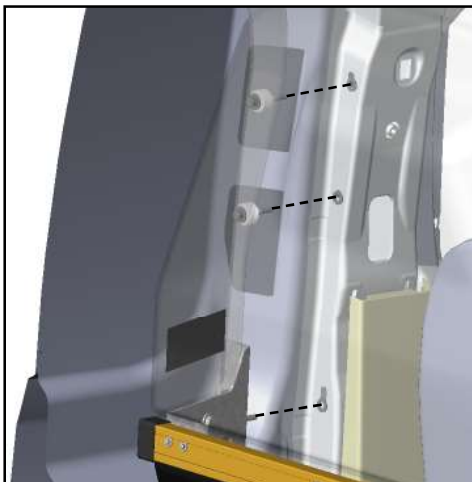

Attach the upper panel to the plusnuts on the driver side of the vehicle.

TOOLS

- Socket Wrench
- 7/16" Socket

2.3.6 Attach the lower panel to the floor bracket.

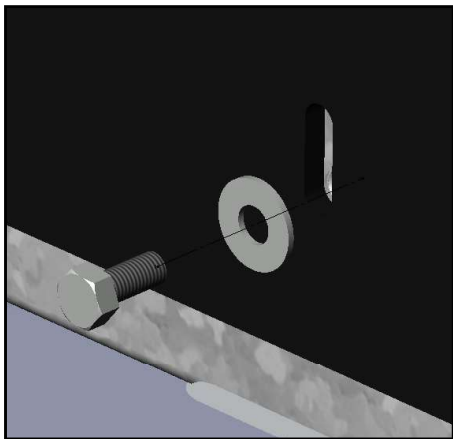

TOOLS

- Cordless Impact
- 1/2" Socket

HARDWARE USED

5x



#90-204 Hex Bolt 5/16" x 3/4"



#98-116 Flat Washer



#94-116 Serrated Nut

2.3.7 Re-attach D-Rings or use hardware to bolt to B-Pillar.



Attach the floor bracket to the floor re-using the 2 D-ring bolts with the addition of the square washers, in between the D-rings and floor bracket.

**Note:** Use 90-010 if D-rings are not available.



**TOOLS**

- Socket Wrench
- 13mm Socket
- T50 Torx Bit

**HARDWARE USED**

2x



2x



#90-010 Screw, Torx 7/16" x 1"

#98-141 Square Flat Washer

2.3.8 Apply the warning label on the passenger side wing.

NOTE: The english warning label is already attached to the upper panel.

WARNING: After installation is complete make sure all the bolts are tighten.



WARNING LABEL

**“You have successfully installed your partition, thank you for doing business with us.”**

For any feedback or suggestions, you may have, please contact: [cs@rangerdesign.com](mailto:cs@rangerdesign.com)