

FASTENER GROUPS LISTED BELOW ARE USED FOR ASSEMBLY AND INSTALLATION. SOME ASSEMBLY DRILLING IS REQUIRED. PARTITION INSTRUCTIONS & FASTENERS ARE WITH THAT UNIT. USE KD UNIT DRAWINGS TO IDENTIFY THEIR SEPARATE PARTS. CUSTOMER SPECIFIED SHELF DIMENSIONS ARE SHOWN HERE.

FASTENERS	QTY	DRILL
-----------	-----	-------

ASSEMBLY FASTENERS

1/4-20 X 1/2" THP:SCW.	(22)	
1/4-20 HX. FLANGE NUT	(22)	9/32
8-32 X 3/8 RHP:SCV	(4)	
8-32 HEX FLANGE NUT	(4)	3/16
10-24 X 1/2 RHP:SCV.	(4)	
10-24 ELASTIC L'NUT	(4)	3/16

INSTALLATION FASTENERS

1/4-20 PLUSNUT *P*	(4)	
1/4-20 X 1-1/2" HH:SCW/FT	(4)	13/32
1/4 PLN WASH	(4)	
1/4 SPLIT RING L'WASHER	(4)	
1/4 PLN. WASH.	(6)	
1/4-20 ELASTIC STOPNUT	(3)	
1/4-20 X 1-1/2 HH SCV FT	(3)	9/32
1/2 PLN. WASHER DC	(3)	
22200-0 PLUSNUT TOOL	(1)	

CARTON (1)

PRINTED DOCUMENT IS UNCONTROLLED



ADRIAN STEEL CO.
906 JAMES STREET
ADRIAN, MI 49221
517/265-6194

#40 BIN KD
14 x 12 1/2 x 42

NOTE:

TOP PANEL COVERS ALL VERTICAL PIECES, & LEG BRACES. LEG BRACES ARE ASSEMBLED INSIDE END PANELS.

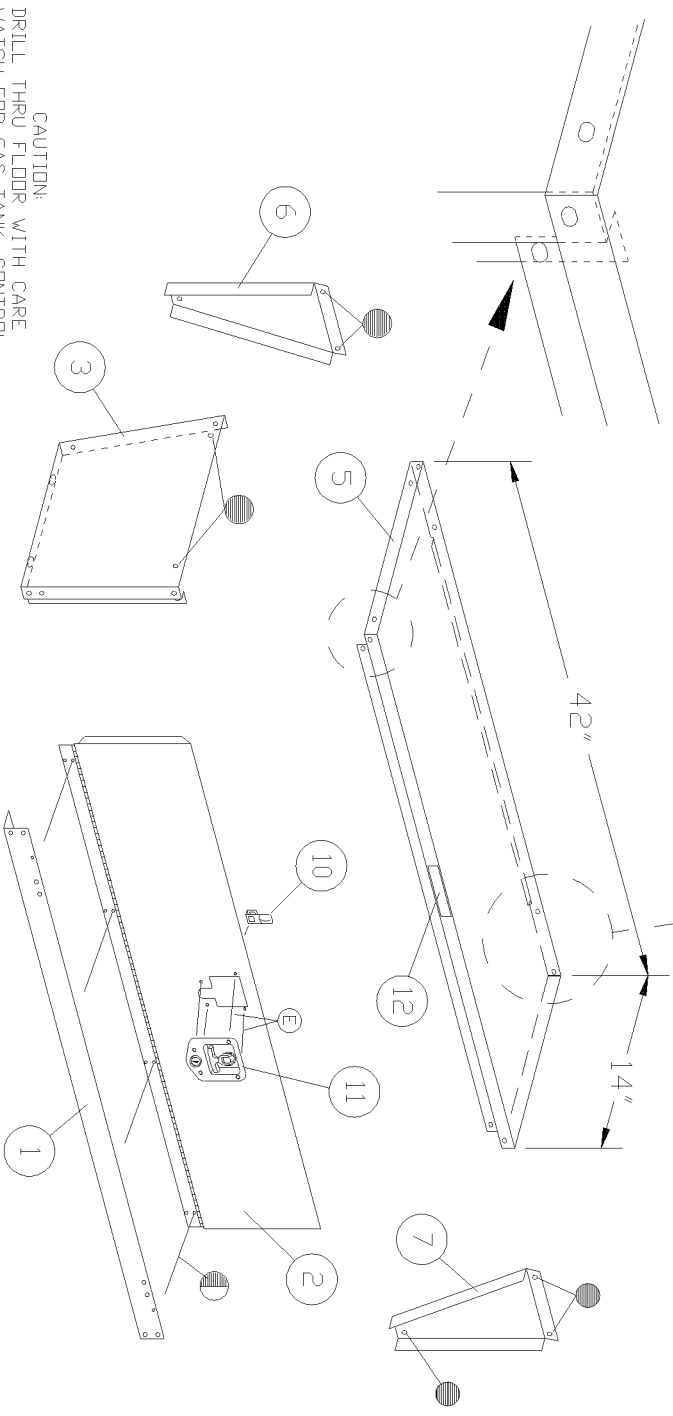
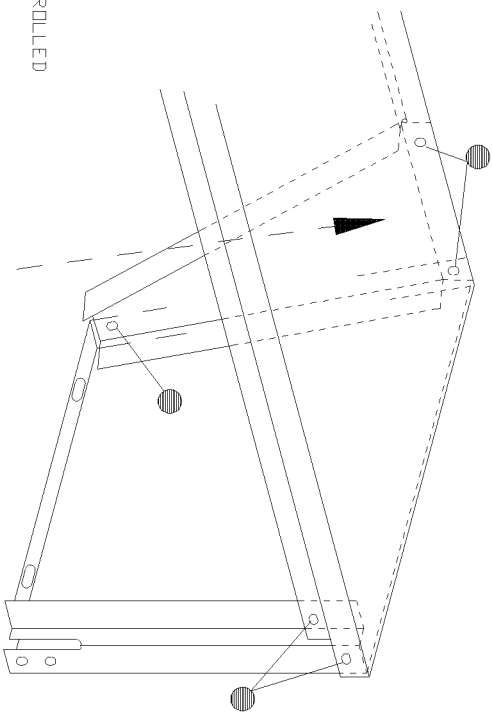

ITEM	PART NO.	DESCRIPTION	QTY.
1	FR42	FLOOR RAIL 42"	1
2	9311	DDDR ASSEMBLY 42" (82239)	1
	11947	END PANEL 14" LEFT	1
	11948	END PANEL 14" RIGHT	1
4	11949	TOP PANEL 14x42	1
5	11949	TOP PANEL 14x42	1
6	12072	LEG BRACE /GALV., LEFT	1
7	12073	LEG BRACE /GALV., RIGHT	1
8	21000	FOLDING TEE HANDLE W/KEYS	1
		CONSIST OF:	
9	20997	KEY SET, FOLDING TEE	1
10	20998	LATCH PAWL, FOLDING TEE	1
11	20999	HANDLE ASSEMBLY, ADSCD	1
12	LOGD-SM	SML LABEL-ASCD	1

33836-0 #40 BOXING INSTRUCTIONS

FRONT VIEW OF COMPLETED

#40 KD BIN ASSEMBLY

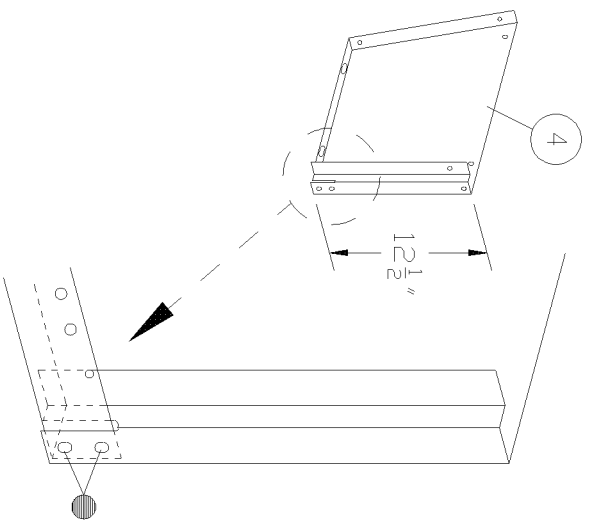
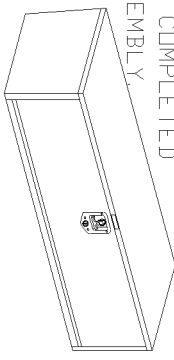

FASTENING PROCEDURES

1. USE NUT & BOLT THRU WHEREVER POSSIBLE.
2. USE PLUSNUTS FOR BLIND FASTENING.
3. USE SHEET METAL SCREWS IN SHEAR ONLY.

CAUTION:
DRILL THRU FLOOR WITH CARE
WATCH FOR GAS TANK, CONTROL
LINES, & ELECTRICAL WIRING.