

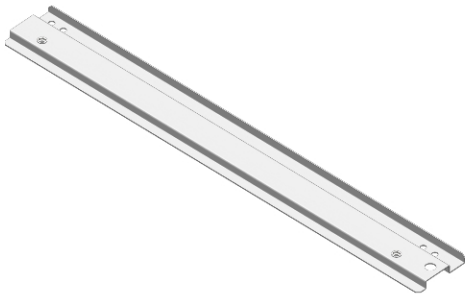

Assembly/Installation Instructions and Owners Manual

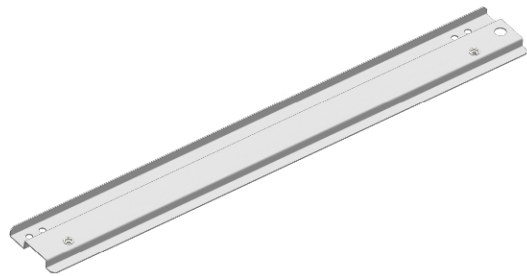

CURB-SIDE



STREET-SIDE

RKNV2-CS & RKNV2-SS RAIL KITS, NV200, SGL

- PRECAUTIONS -



CAUTION
THE USE AIR IMPACT TOOLS CAN
OVER-TORQUE FASTENERS AND
CAUSE FASTENER FAILURE!



CAUTION
ALL INSTALLATION HOLES SHOULD BE SEALED
WITH SILICON OR BUTYL SEALANT TO PREVENT
EXHAUST FUMES FROM ENTERING THE VEHICLE!



DANGER
INSPECT FOR FUEL TANK, FUEL LINES, BRAKE LINES, HIGH
VOLTAGE BATTERIES AND ELECTRICAL LINES PRIOR TO
DRILLING TO AVOID DAMAGING CRITICAL VEHICLE SYSTEMS
OR INJURY TO INSTALLER DURING INSTALLATION PROCESS!



CAUTION
TO AVOID DAMAGING THE VEHICLE ALWAYS
USE DRILL STOPS WHEN DRILLING ANY IN-
STALLATION HOLES!



- IMPORTANT WARRANTY REQUIREMENTS -

1. SUBSTITUTING ADRIAN STEEL SPECIFIED FASTENERS FOR ASSEMBLY AND/OR INSTALLATION WILL VOID YOUR PRODUCT WARRANTY.
2. ALL HOLES DRILLED INTO VEHICLE SHOULD HAVE THE RAW METAL EDGES SEALED WITH A SELF-ETCHING PRIMER TO RESIST CORROSION AND POTENTIAL FASTENER POINT FAILURE.
3. ALL FASTENERS USED IN THE INSTALLATION OF THIS PRODUCT SHOULD BE TIGHTENED TO THE TORQUE(S) SPECIFIED IN THESE INSTRUCTIONS.
4. THESE INSTRUCTIONS SHOULD BE KEPT WITH THE VEHICLE.

THE BASIC TOOLS NEEDED FOR MOST INSTALLATIONS



DRILL



DRILL BIT WITH
STOP



RATCHET, SOCKETS
AND/OR WRENCHES



SCREWDRIVERS





MEASURING TAPE

ADDITIONAL TOOLS MAY BE NEEDED FOR THIS INSTALLATION AND THEY WILL BE IDENTIFIED IN THE STEPS THAT FOLLOW.



WHEN INSTALLING PLUSNUTS MAKE SURE YOU USE THE CORRECT DRILL BIT WITH A STOP!





PLUSNUT SIZE	DRILL BIT SIZE
1/4-20 PLUSNUT, FAS0052	USE A 3/8" DIAMETER DRILL BIT WITH A STOP.
5/16-18 PLUSNUT, FAS0091	USE A 1/2" DIAMETER DRILL BIT WITH A STOP.

 OR
 
NOTE: A PLUSNUT SETTING TOOL IS REQUIRED FOR PLUSNUT INSTALLATION AND IS NOT SUPPLIED WITH THIS KIT. ORDER PLUSNUT TOOLS FROM ADRIAN STEEL (P.N. 22200-0) OR USE AN AIR POWERED PLUSNUT SETTING GUN.

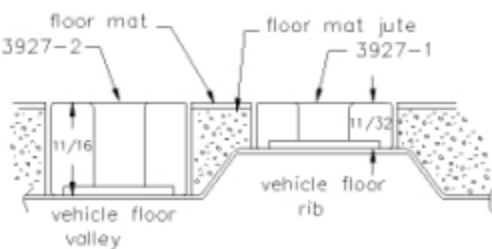
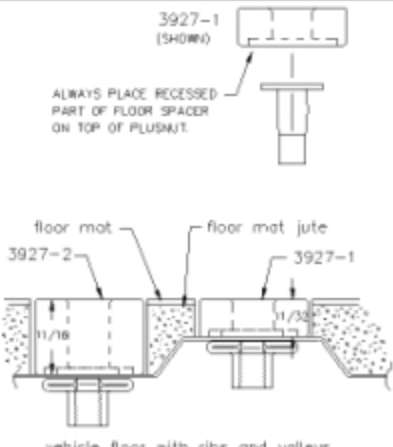
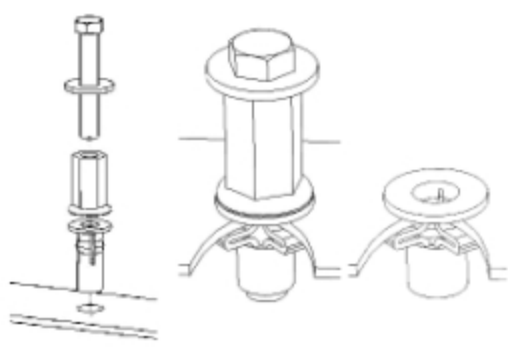
NOTE: If your vehicle contains carpet or a rubber floor mat you will need to prepare the mounting locations using a 1-3/16" carpet cutter.

1-3/16" DIAMETER CARPET CUTTER P.N. 31183-0.

	<p>Step 01 Optional</p>	<p>If your vehicle contains carpet or a rubber floor mat you will need to prepare the mounting locations. (if not, skip to STEP 02)</p> <p>Position the product to be installed into the vehicle and once you are satisfied with the mounting locations, mark the mounting locations. Using a 1-3/16" diameter carpet cutter. Select the appropriate floor spacers as shown in the illustration to the left. Set those aside for use later into the installation process.</p> <p>Once you have prepared the carpet/floor mat for</p>
	<p>Step 02 Prepare Mounting Locations</p>	<p>Using a drill and drill bit (see table at top of page for correct size) drill the mounting holes in the vehicle sheet metal to prepare for installing the plusnuts.</p> <p>If you are thru-bolting at any of the locations simply drill a hole that is 1/16" larger than the bolt size(s) for those locations.</p> <p>Once you have drilled the holes into the vehicle, the raw metal edges should be sealed using a self-etching primer to resist corrosion and potential fastener point failure.</p>
	<p>Step 03 Setting Plusnuts</p>	<p>Use a Air Powered Plusnut Setting Gun to "set the plusnut" or if installing manually with hand tools, assemble the following:</p> <p>1/4-20UNC Plusnut (FAS0052) FAS0080 SCREW, HXHD, 1/4-20UNCx2.00", G8 FAS0067 WASHER, FLAT, 1/4"ID 22200-0 PLUSNUT TOOL</p> <p>5/16-18UNC Plusnut (FAS0091) FAS0095 SCREW, HXHD, 5/16-18UNCx2.00", G8 FAS0086 WASHER, FLAT, 5/16"ID 22200-0 PLUSNUT TOOL</p> <p>Place barrel of the plusnut body in sheet metal thru hole until flange is flush with sheet metal.</p> <p>Using a 9/16" combination wrench of plusnut tool body and a second hand wrench, ratchet, or air tool, rotate the hex bolt head CW to draw plus nut flanges up (set the plusnut).</p> <p>Remove hex bolt, washer, and plusnut. Inspect installation.</p>

PARTS YOU WILL USE FOR STEP 04	43729-G MOUNTING CHANNEL ASSM. (1) REQUIRED	03927-1 SHORT SPACER (2) REQUIRED	FAS0741 M8-1.25 x 30MM, BHCS (2) REQUIRED	FAS0098 5/16 LOCKWASHER (2) REQUIRED
				
	FAS0086 5/16 WASHER (2) REQUIRED			
				



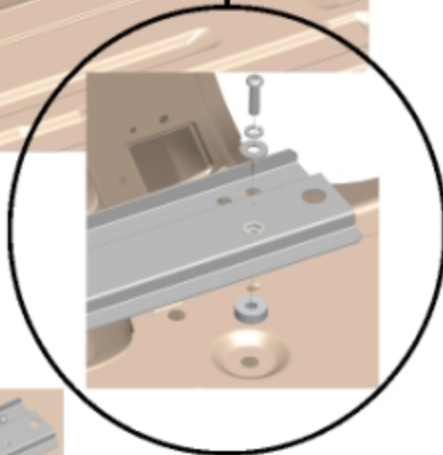





Instructions for Step 04



COMPLETED STEP

Locate the two floor mounting weld nuts in the vehicle floor (if a floor-mat is present cut 1-1/4" holes in floor-mat for access). Place a short floor spacer over each weld-nut position in floor.

Place floor rail (street-side shown) in position as shown and bolt into place using the M8 BHCS, lock washer and flat washer for each position. Tighten both bolts to secure the mounting channel in place.

PARTS YOU WILL USE FOR STEP 05	43710-G D-BRKT, NV200, SS (1) REQUIRED	43711-G C-BRKT, NV200, SS (1) REQUIRED	43712-G D-BRKT, NV200, CS (1) REQUIRED	43713-G C-BRKT, NV200, CS (1) REQUIRED
	 STREET-SIDE	 OR  STREET-SIDE	 CURB-SIDE	 CURB-SIDE
	FAS0741 M8-1.25 x 30MM, BHCS (3) REQUIRED	FAS0086 5/16 WASHER (3) REQUIRED	FAS0098 5/16 LOCKWASHER (3) REQUIRED	
				

Instructions for Step 05

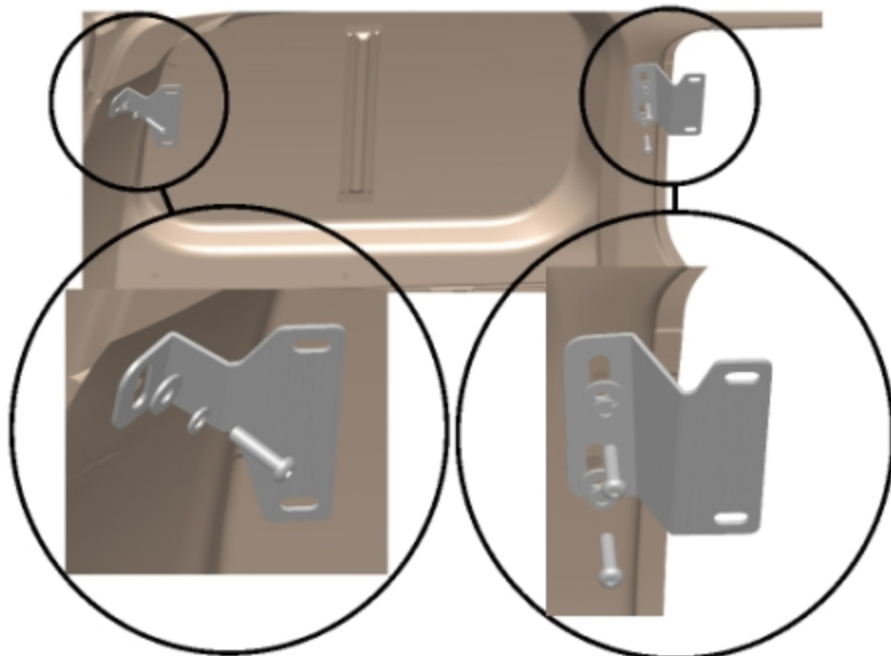





Locate the two weld nuts in the vehicle c-pillar area and the weld nut in the d-pillar area as shown.

Position the mounting brackets into place as shown (street-side shown, curb-side is opposite using 43712-G & 43713-G) and temporarily secure using the M8 BHCS, lock washers and flat washers as shown. Final tightening of brackets will be completed after shelving unit is in place.

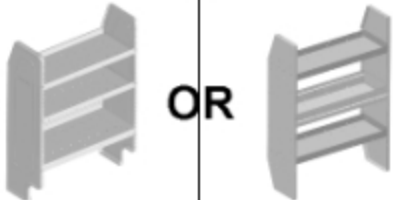

COMPLETED STEP



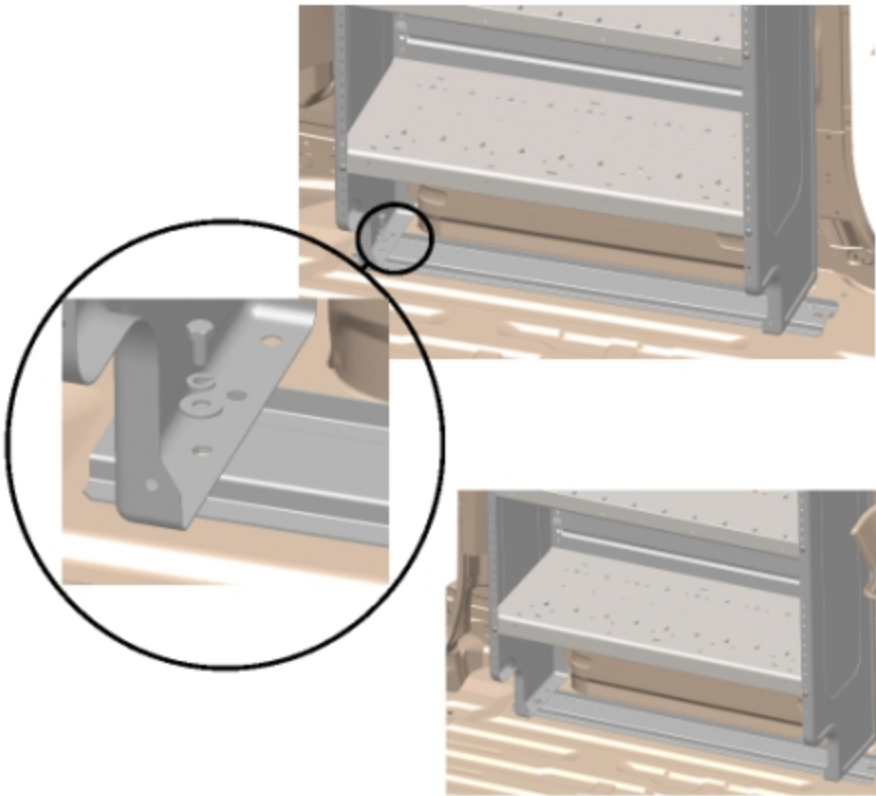

PARTS YOU WILL USE FOR STEP 06	AD32FP AD32FP SHELF UNIT	HD32NV2 HD12X32SHELF ASSM	FAS0165 5/16-18 x .62 HEX SREW (2) REQUIRED	FAS0086 5/16 WASHER (2) REQUIRED
				
	FAS0098 5/16 LOCKWASHER (2) REQUIRED			
				

Instructions for Step 06

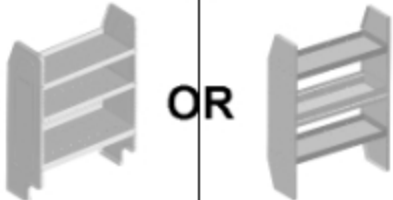

COMPLETED STEP

Position the appropriate shelving unit (AD32FP or HD32NV2) in place as shown and bolt to floor mounting channel as shown using the 5/16 hex screws, lock washers and flat washers as shown.

PARTS YOU WILL USE FOR STEP 07	AD32FP AD32FP SHELF UNIT	HD32NV2 HD12X32SHELF ASSM	FAS0165 5/16-18 x .62 HEX SREW (2) REQUIRED	FAS0090 5/16 NYLOCK NUT (4) REQUIRED
				
	FAS0086 5/16 WASHER (2) REQUIRED			
				

Instructions for Step 07

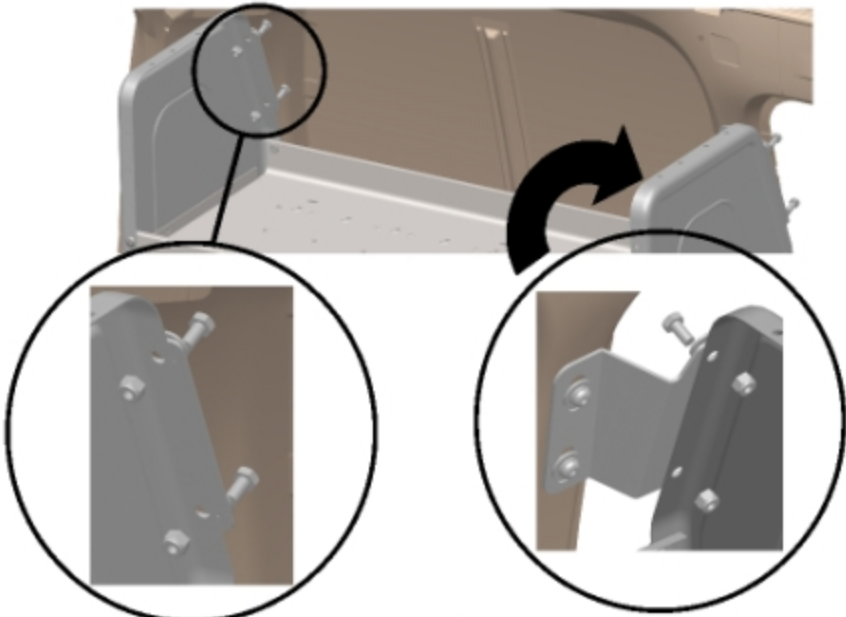
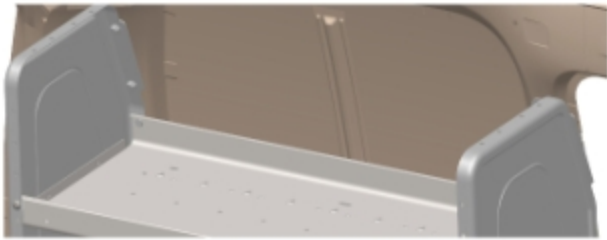
COMPLETED STEP

To complete the shelving installation secure the mounting brackets to the top of the shelving end panels as shown using the 5/16 hex screws, flat washers and nylock nuts as shown. Once the mounting bracket fasteners are in place you should also finish tightening the M8 BHCS that secure the mounting brackets to the vehicle.

Repeat this process if you are installing a shelving unit on the opposite side of the vehicle.

Your installation is now complete!