

FASTENERS SHOWN LISTED BELOW ARE USED FOR ASSEMBLY UNLESS OTHERWISE NOTED. SOME ASSEMBLY DRILLING IS REQUIRED. DRAWING NOTATIONS & FASTENERS ARE WITH PARTS. USE KID UN-1 DRAWINGS TO OBTAIN LIST OF SEPARATE PARTS. CUSTOMER SPECIFIED STEEL DIMENSIONS ARE SHOWN HERE.

 ADRIAN STEEL CO.
906 JAMES STREET
ADRIAN, MI 49221
517/265-6194

MD602 DWR/CAB MOD

DWG BY: ECN# 8329 DATE: 08/23/05
 PACKAGE WEIGHT: 100.92 #
 PART NO. 100.92 #
 MD 602
 PARTS/ASSEMBLY & MATERIAL
 PRICE: 9.00 VALUE: 28.00

ITEM	PART NO.	DESCRIPTION	QTY.
1	10388-1	MOUNT BRACKET W/O FAS	1
2	4B	PARTS TRAY 2x12x18	1
3	8	3-DRAWER MEDIUM	3
4	MB118	MOUNT ANGLE 1-1/2" / GALV	2
5	MB120	STRAP.BRKT.13-1/2" / GALV	1

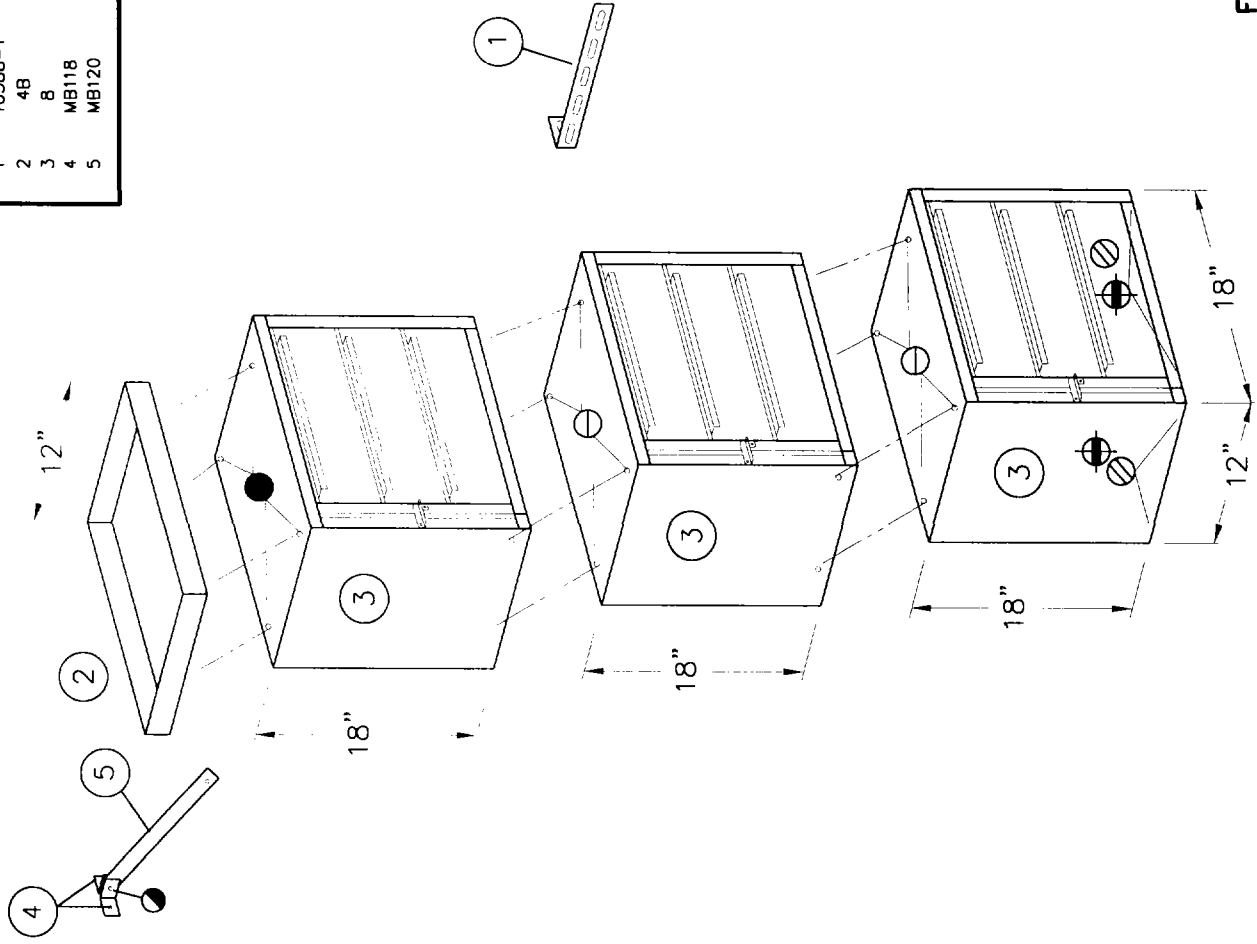

SYM.	FASTENERS	QTY	DRILL
⊖	ASSEMBLY FASTENERS		
⊖	{ #14 x 3/4" THP.SCW.	{ (12)	{ 3/16
●	{ 1/4 EXT.TOOTH L'WASH.	{ (12)	{
●	{ 1/4-20 x 1/2" THP.SCW.	{ (24)	{ 9/32
●	{ 1/4-20 HX. FLANGE NUT	{ (24)	{
●	{ 1/4-20 x 3/4" HX.HD.SCW.	{ (2)	{ 9/32
●	{ 1/4-20 HX. FLANGE NUT	{ (4)	{
●	INSTALLATION FASTENERS		
●	{ 1/4-20 PLUSNUT "PB"	{ (2)	{
●	{ 1/4-20 x 1" HH.SCW.FT	{ (2)	{ 3/8
●	{ 1/4 PLN WASH	{ (2)	{
●	{ 1/4 SPLIT RING L'WASHER	{ (2)	{
●	{ 5/16-18 PLUSNUT "PB"	{ (3)	{ 1/2
●	{ 5/16-18 x 1-1/2" HH.SCW.FT	{ (3)	{
●	{ 5/16 PLN WASH	{ (3)	{
●	{ 5/16 SPLIT RING L'WASHER	{ (3)	{
●	{ 5/16 PLN. WASHER	{ (6)	{
●	{ 5/16-18 HX.STOP NUT	{ (3)	{ 11/32
●	{ 5/16-18 x 1-1/2" HH.SCW.FT	{ (3)	{
●	{ 1/2 PLN. WASHER	{ (3)	{
●	22200 PLUSNUT TOOL N/C	(1)	

FASTENING PROCEDURES

1. USE NUT & BOLT THRU WHEREVER POSSIBLE.
2. USE PLUSNUTS FOR BLIND FASTENING.
3. USE SHEET METAL SCREWS IN SHEAR ONLY.

CAUTION:
 DRILL THRU FLOOR WITH CARE
 WATCH FOR GAS TANK, CONTROL
 LINES, & ELECTRICAL WIRING.