

FASTENER GROUPS LISTED BELOW ARE USED FOR ASSEMBLY AND INSTALLATION. SOME ASSEMBLY DRILLING IS REQUIRED. PARTS ON INSTRUCTIONS & FASTENERS ARE WITH THAT UNIT. USE KD UNIT DRAWINGS TO IDENTIFY HILIR SEPARATE PARTS. CUSTOMER SPECIFIED SHELF DIMENSIONS ARE SHOWN THERE



ADRIAN STEEL CO.
906 JAMES STREET
ADRIAN, MI 49221
517/265-6194

MD601 DWR/CAB MOD

DWG. BY	ECN#	DATE	CHK'D. BY	PACKAGE#	ISS
BTS	8329	8/23/05	PLA	MD 601	B
PACKAGE WEIGHT -	79.79 #		HORIZONTAL & VERTICAL	HCC= 9.00	VCC= 28.00
ITEM	PART NO.	DESCRIPTION	QTY.		

1	10388-1	MOUNT BRACKET W/O FAS	1
2	12	CABINET 12x22x18	2
3	12A	END. #12 & KD 11x21	2
4	919	3-DRAWER COMBO	1
5	MB11B	MOUNT ANGLE 1-1/2" / GALV	2
6	MB120	STRAP BRKT. 1.5-1/2" / GALV	1

FASTENERS

QTY DRILL

ASSEMBLY FASTENERS

⊖	{ #14 x 3/4 THP. SCW.	(10)	}	3/16
⊖	{ 1/4 EXT. TOOTH L'WASHER	(10)	}	
●	{ 1/4-20 x 1/2" THP SCW.	(12)	}	9/32
●	{ 1/4-20 HX. FLANGE NUT	(12)	}	
●	{ 1/4-20 x 3/4" HX.HD SCW.	(2)	}	9/32
●	{ 1/4-20 HX. FLANGE NUT	(4)	}	
●	{ 1/4-20 x 3/8" THP SCW.	(4)	}	9/32
●	{ 1/4 EXT. TOOTH L'WASHER	(4)	}	

INSTALLATION FASTENERS

⊖	{ 1/4-20 PLUSNUT "PB"	(2)	}	3/8
⊖	{ 1/4-20 x 1" HH.SCW.FT	(2)	}	
⊖	{ 1/4 PLN WASH	(2)	}	
⊖	{ 1/4 SPLIT RING L'WASHER	(2)	}	
⊖	{ 5/16-18 PLUSNUT "PB"	(3)	}	1/2
⊖	{ 5/16-18 x 1-1/2" HH.SCW.FT	(3)	}	
⊖	{ 5/16 PLN WASH	(3)	}	
⊖	{ 5/16 SPLIT RING L'WASHER	(3)	}	
⊖	{ 5/16 PLN. WASHER	(6)	}	
⊖	{ 5/16-18 HX.STOP NUT	(3)	}	
⊖	{ 5/16-18 x 1-1/2" HH.SCW.FT	(3)	}	11/32
⊖	{ 1/2 PLN. WASHER	(3)	}	
⊖	{ 22200 PLUSNUT TOOL N/C	(1)	}	

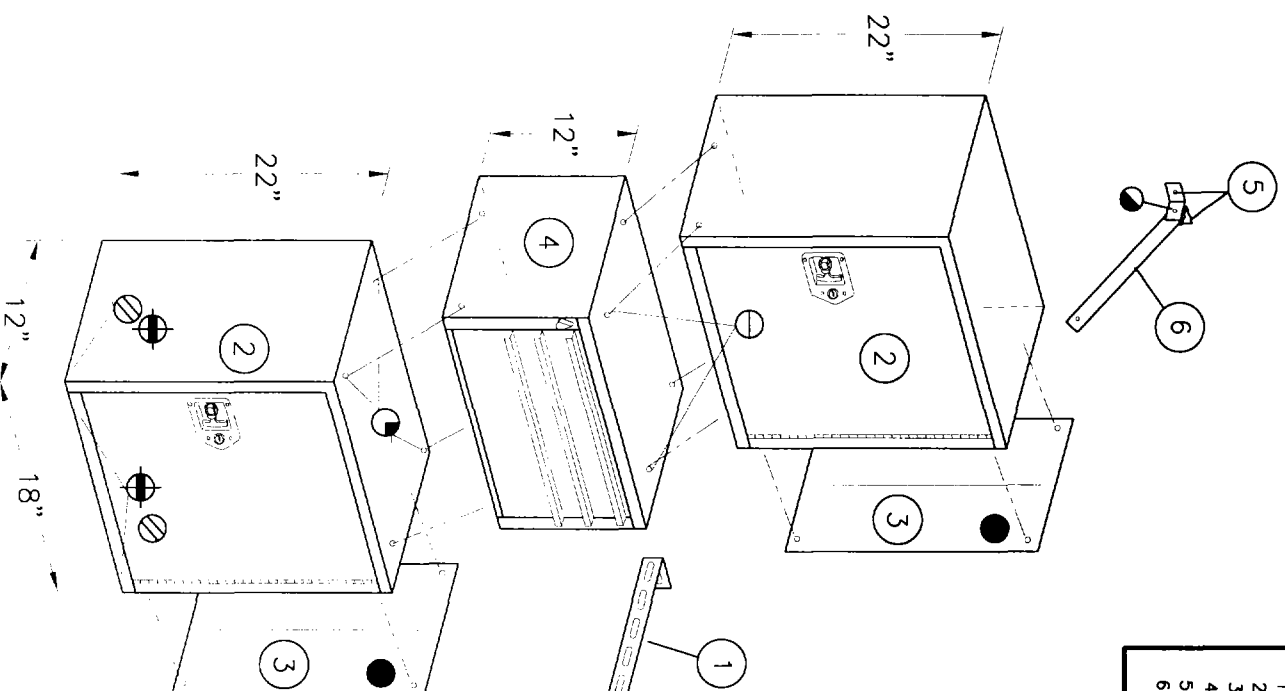

FASTENING PROCEDURES

1. USE NUT & BOLT THRU WHEREVER POSSIBLE
2. USE PLUSNUTS FOR BLIND FASTENING.
3. USE SHEET METAL SCREWS IN SHEAR ONLY.

CAUTION:

DRILL THRU FLOOR WITH CARE
WATCH FOR GAS TANK, CONTROL
LINES, & ELECTRICAL WIRING

A-MD601