

FASTENER GROUPS LISTED BELOW ARE USED FOR ASSEMBLY AND INSTALLATION. **SOME ASSEMBLY DRILLING IS REQUIRED.** PARTITION INSTRUCTIONS & FASTENERS ARE WITH THAT UNIT. USE KD UNIT DRAWINGS TO IDENTIFY THEIR SEPARATE PARTS. CUSTOMER SPECIFIED SHELL DIMENSIONS ARE SHOWN HERE.

SYM.	FASTENERS	QTY.	DRILL
●	{ 1/4-20 x 1/2" THP.SCW. 1/4-20 HX. FLANGE NUT	{ (32) (32)	9/32
●	{ 1/4-20 x 3/4" HX.HD.SCW. 1/4-20 HX. FLANGE NUT	{ (4) (8)	9/32
●	INSTALLATION FASTENERS 1/4-20 PLUSNUT "PB" 1/4-20 x 1" HH.SCW.FT	{ (4) (4)	13/32
●	1/4 PLN WASH 1/4 SPLIT RING L'WASHER 1/4-20 PLUSNUT "PB" 1/4-20 x 1-1/2" HH.SCW.FT	{ (4) (4) (3) (3)	13/32
●	1/4 PLN WASH 1/4 SPLIT RING L'WASHER 1/4 PLN. WASHER 1/4-20 HX.STOP NUT 1/4-20 x 1-1/2" HH.SCW.FT	{ (3) (3) (6) (3) (3)	9/32
	1/2 PLN. WASHER PLUSNUT TOOL	(3) (1)	

ADRIAN STEEL CO.
906 JAMES STREET
ADRIAN, MI 49221
517/285-6194

MD531 MODULE SPECIAL
HD KD SHELF UNIT
14 x 46 x 42

DWG BY: ECN# 7398 DATE 6/04/04 CHK'D BY: RLD PACKAGE # ISS: MD531 A
PACKAGE WEIGHT- 92.35 # REF 20364

ITEM	PART NO.	DESCRIPTION	QTY.
1	DK542	DOOR KIT #50/50-42	1
2	DVI4	DIVIDER/PNTD: #50KD	4
3	29263	KD UNIT SPECL 14x46x42 HD	1
	EP1446	END PANEL KD 46"	2
	FR42	FLOOR RAIL 42"	1
	GS6x10LH	GUSSET LH #50-#30 KD's	1
	GS6x10RH	GUSSET RH #50-#30 KD's	1
	GS6x6	GUSSET, 6" TRIANGLE	2
	MB118	MOUNT ANGLE 1-1/2" / GAL	4
	MB120	STRAP, BRKT. 13-1/2" / GAL	2
	SF21242	SHELF 2x12x42	1
	SF21442	SHELF 30/50KD 2x14x42	1
	SF41442	SHELF HD-KD 4x14x42	1

HEIGHT FROM FLOOR TO LOWEST SHELF WILL VARY DEPENDING ON THE HEIGHT OF YOUR VEHICLES WHEELHOUSE.
PLEASE REFER TO THE INTERIOR INSTALLATION SHEET FOR CORRECT SHELF HEIGHT BEFORE ASSEMBLY.

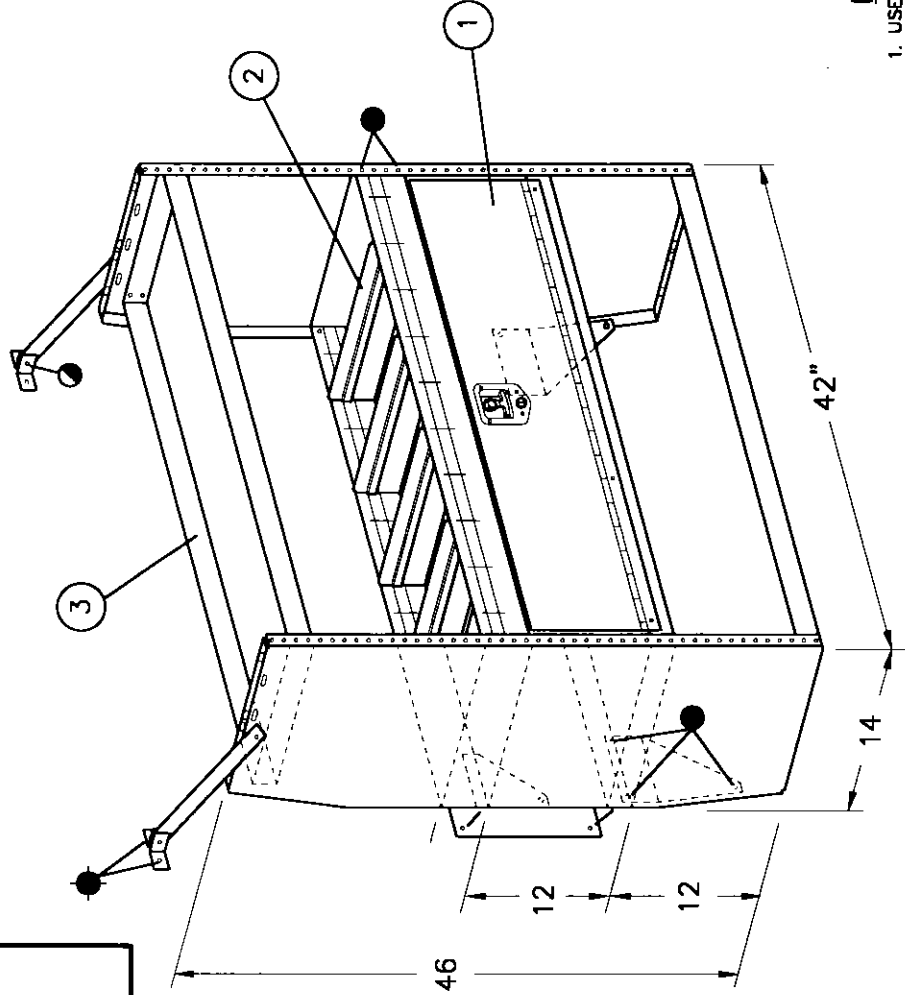

CAUTION:
DRILL THRU FLOOR WITH CARE
WATCH FOR GAS TANK, CONTROL
LINES, & ELECTRICAL WIRING.

FASTENING PROCEDURES

1. USE NUT & BOLT THRU WHEREVER POSSIBLE.
2. USE PLUSNUTS FOR BLIND FASTENING.
3. USE SHEET METAL SCREWS IN SHEAR ONLY.