

FASTENER GROUPS LISTED BELOW ARE USED FOR ASSEMBLY AND INSTALLATION. SOME ASSEMBLY DRILLING IS REQUIRED. PARTITION INSTRUCTIONS & FASTENERS ARE WITH THAT UNIT. USE KD UNIT DRAWINGS TO IDENTIFY THEIR SEPARATE PARTS. CUSTOMER SPECIFIED SHELF DIMENSIONS ARE SHOWN HERE.

SYM. FASTENERS QTY DRILL

ASSEMBLY FASTENERS

- { 1/4-20 x 1/2" THP,SCW. (38) } 9/32"
- { 1/4-20 HX. FLANGE NUT (38) } 9/32"
- ◐ { 1/4-20 x 3/4" HH,HD,SCW. (4) } 9/32"
- ◑ { 1/4-20 HX. FLANGE NUT (4) } 9/32"

INSTALLATION FASTENERS

- { 1/4-20 PLUSNUT *PB* (4) } 3/8"
- { 1/4-20 x 1" HH,SCW/FT (4) } 3/8"
- { 1/4 PLN WASH (4) } 3/8"
- { 1/4 SPLIT RING L/WASHER (4) } 3/8"
- { 5/16-18 PLUSNUT *PB* (4) } 1/2"
- { 5/16-18 x 1-1/2" HH,SCW. (4) } 1/2"
- { 5/16 PLN WASH (4) } 1/2"
- { 5/16 SPLIT RING L/WASHER (4) } 1/2"



ADRIAN STEEL CO.
906 JAMES STREET
ADRIAN, MI 49221
517/265-6194

HD KD SHELF UNIT
14 X 46 X 42

HEIGHT FROM FLOOR TO LOWEST SHELF WILL VARY DEPENDING ON THE HEIGHT OF YOUR VEHICLES WHEELHOUSE.
PLEASE REFER TO THE INTERIOR INSTALLATION SHEET FOR CORRECT SHELF HEIGHT BEFORE ASSEMBLY.

DWG BY	ECN#	DATE	CHK'D BY	PACKAGE#	ISS.
BTS	14431	07/09/2012		HD-42FP	C
PACKAGE WEIGHT-	79.01 #	REF 20964			
ITEM	PART NO.	DESCRIPTION	QTY.		
1	GS6X6	GUSSET 6"	2		
2	FR42	FLOOR RAIL 42"	1		
3	MB120	STRAP BRACKET	2		
4	MB18	MOUNT ANGLE	4		
5	SF21242	SHELF 2X12X42	1		
6	EP1446	END PANEL KD 46"	2		
7	SF41442	HD SHELF 4X14X42	2		
8	GS6X10RH	GUSSET RH	1		
9	GS6X10LH	GUSSET LH	1		

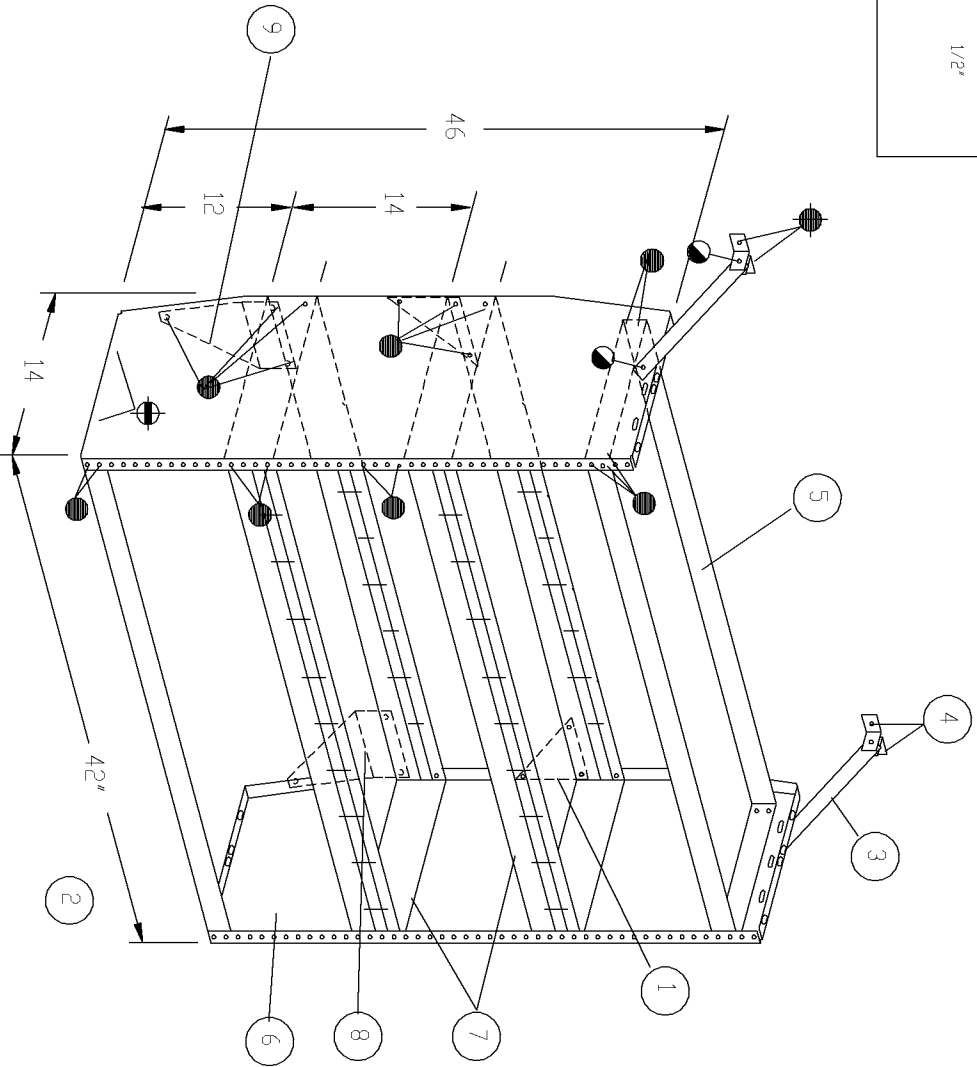

CAUTION:
DRILL THRU FLOOR WITH CARE
MATCH FOR GAS TANK, CONTROL
LINES, & ELECTRICAL WIRING.