



Closed End Adjustable KD Shelving Unit Assembly

P.N.: 37960

ISSUE: C

CHK.BY:

REV.BY: dcs

DWG.BY: BTS

ECN- 12482 DATE: 10-5-2009

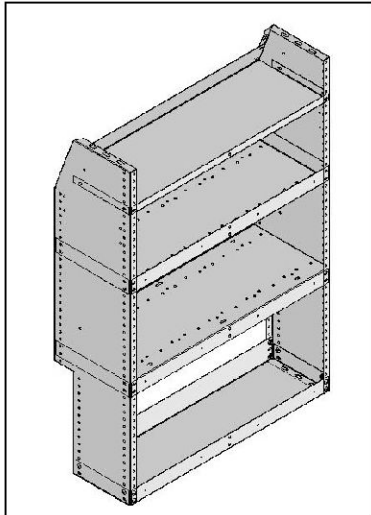

HD32TC
12 x 32 x 46

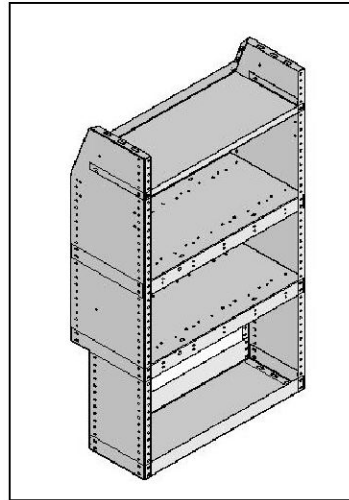

HD26TC
12 x 26 x 46

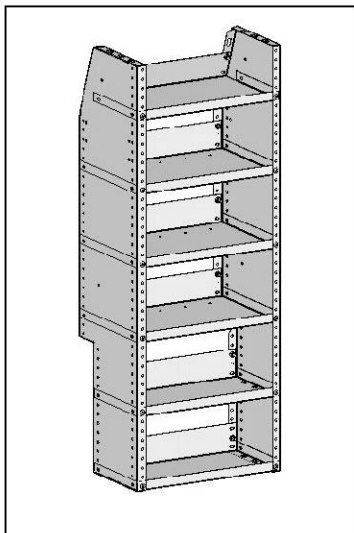

HD17TC
12 x 17 x 46

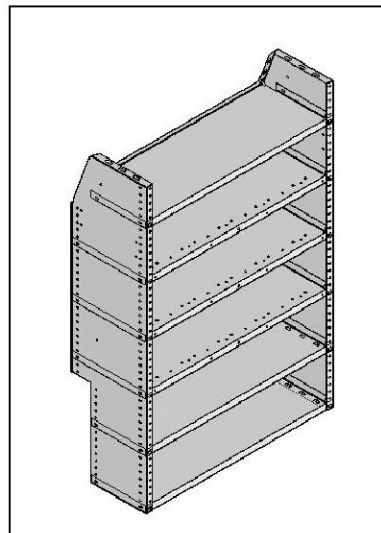

HD30TC
12 x 30 x 46

NOTE: WHEN INSTALLING KD UNITS ON STREET SIDE. REMOVE JACK AND ASSOCIATED EQUIPMENT AND STOW. ALSO REPLACE PLASTIC JACK COVER BEFORE MOUNTING KD UNIT ON STREET SIDE.

ADRIAN STEEL COMPANY • 906 JAMES ST. • ADRIAN, MI. 49221 • (517) 265-6194

Adjustable KD Shelf Unit Assembly

BEFORE YOU START!

IMPORTANT INSTALLATION STEPS ARE DENOTED USING A STOP SIGN. THESE STEPS MUST BE PERFORMED AS SPECIFIED IN ORDER TO ENSURE A PROPER INSTALLATION AND MUST BE FOLLOWED IN ORDER TO MAINTAIN YOUR PRODUCT WARRANTY!



CRITICAL INFORMATION PERTAINING TO USER AND/OR VEHICLE SAFETY IS DENOTED USING A CAUTION SIGN. SAFETY ITEMS MUST BE STRICTLY ADHERED TO IN ORDER TO ENSURE A SAFE WORKING ENVIRONMENT!



YOU WILL NEED THE FOLLOWING TOOLS IN ORDER TO COMPLETE THIS JOB.

#3 PHILLIPS SCREWDRIVER	
7/16" OPEN END WRENCH	RATCHET WRENCH, WITH 7/16" SOCKET







ALL FASTENERS USED IN THE ASSEMBLY AND INSTALLATION OF THIS PRODUCT SHOULD BE TIGHTENED TO THE SPECIFIED TORQUE AS LISTED WITH EACH FASTENER CALLOUT BOX.



THE USE OF AIR OR ELECTRIC IMPACT TOOLS FOR THE ASSEMBLY OF FASTENERS IS NOT RECOMMENDED AND COULD CAUSE FASTENER FAILURE!



STEP – 01 TABLE OF CONTENTS (TYPICAL KD SHELF UNIT)

 FAS0055 1/2-20UNC HEX FLANGE NUT 8 FT-LBS TORQUE	 FAS0061 1/2-20UNC X 0/50" TRUSS HEAD PHILLIPS SCREW	 EP1246TCLH END PANEL LEFT	 EP1246TCRH END PANEL RIGHT
 TOP SHELF 11" WIDE W/ SLANTED BACK SF11117T FOR HD17TC SF11126 FOR HD26TC SF11130T FOR HD30TC SF11132 FOR HD32TC	 MIDDLE SHELF 12" WIDE SF11217 FOR HD17TC SF21226 FOR HD26TC SF11230TC FOR HD30TC SF21232TC FOR HD32TC	 BOTTOM SHELF 9" WIDE SF10917 FOR HD17TC SF2926 FOR HD26TC SF10930 FOR HD30TC SF2932 FOR HD32TC	

ADRIAN STEEL COMPANY • 906 JAMES ST. • ADRIAN, MI. 49221 • (517) 265-6194

Adjustable KD Shelf Unit Assembly

STEP – 02 BOTTOM / MIDDLE SHELF TO END PNL ASM

The pictures shown below represent fastener pattern for the middle and bottom shelves with the 2" front lip and the 3" back lip. Hand tighten only all fasteners at this time.

Front of Shelf Unit
(Bottom Shelf)

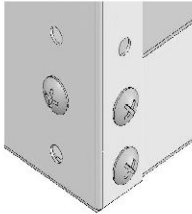

Back of Shelf Unit
(Bottom Shelf)

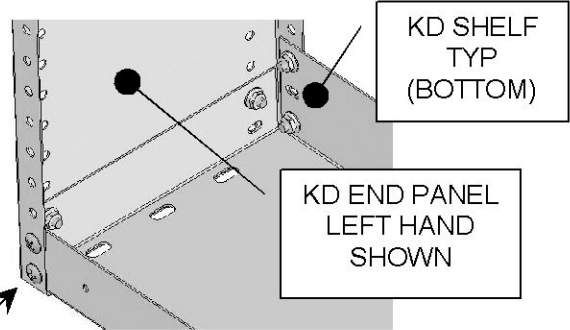
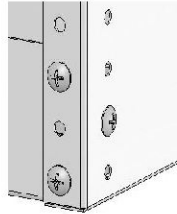

SCREW, THP, 1/4-20UNC X 1/2"
 FAS0061
 NUT, HEX FLNG HD, 1/4-20UNC
 FAS0055

NOTE:
TIGHTEN THESE TWO END PANEL FASTENERS FIRST PRIOR TO TIGHTENING THE REMAINING FRONT AND BACK SHELF FLANGE FASTENERS

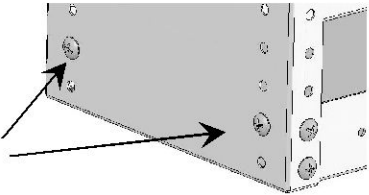

STEP – 03 TOP SHELF TO END PNL ASM

The pictures shown below represent fastener pattern for the top shelf with either a 1" lip or 2" front lip..

Front of Shelf Unit
(Top Shelf)
 HD17TC, HD26TC,
 HD30TC, HD32TC

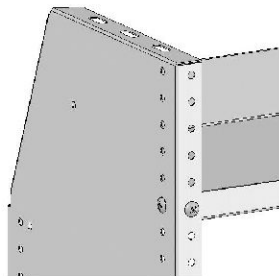

Back of Shelf Unit
(Top Shelf)
 HD17TC, HD26TC,
 HD32TC

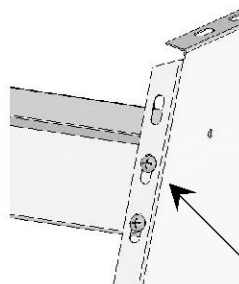

Back of Shelf Unit
(Top Shelf)
 HD30TC

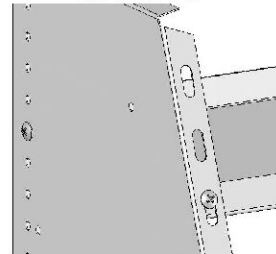

SCREW, THP, 1/4-20UNC X 1/2"
 FAS0061
 NUT, HEX FLNG HD, 1/4-20UNC
 FAS0055

Adjustable KD Shelf Unit Assembly

STEP – 04 MIDDLE / BOTTOM SHELF (w/ 1" LIP) TO END PNL ASM

The pictures shown below represent fastener pattern for the middle shelf with a 1" lip.

Front of Shelf Unit
(Middle Shelf)
HD30TC

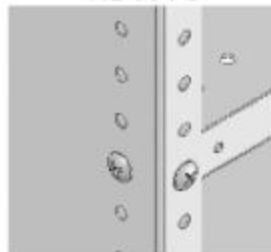

Back of Shelf Unit
(Middle Shelf)
HD30TC

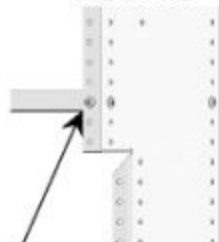

SCREW, THP, 1/4-20UNC X 1/2"
FAS0061
NUT, HEX FLNG HD, 1/4-20UNC
FAS0055

NOTE:
WHEN TWO KD SHELVING
UNITS ARE TO BE INSTALL SIDE
BY SIDE ALL FASTENERS
SHOWN IN IMAGE AT RIGHT
MUST BE REMOVED AND
MATING END PANELS SECURED
WITH FASTENERS PER PDS
DRAWING

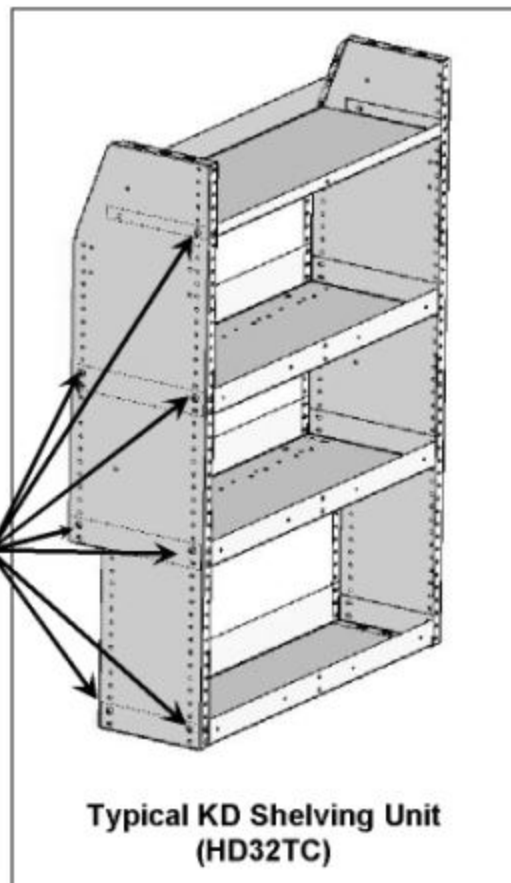

Typical KD Shelving Unit
(HD32TC)

THE ABOVE STEPS SHOW HOW TO ASSEMBLE THE (4) SHELF UNITS.

PLEASE SEE THE PDS FOR THE PROPER HEIGHTS OF THE SHELVES IN THE DIFFERENT UNITS.

THERE MAY BE EXTRA FASTENERS WHEN SHELVING UNITS ARE COMPLETELY ASSEMBLED CORRECTLY

STOP

**DOUBLE-CHECK ALL FASTENER LOCATIONS TO BE
SURE THAT ALL FASTENERS ARE TIGHTENED TO
SPECIFICATIONS!**

STOP

YOUR AS IS NOW COMPLETE! STOW THIS COPY IN THE VEHICLE FOR FUTURE REFERANCE!