

ASSEMBLY FASTENERS	QTY
1/4-20 X 1/2 THP SCW	28
1/4-20 HEX FLANGE NUT	28
INSTALLATION FASTENERS	QTY
5/16-18 PLUSNUT	4
5/16-18 X 1 5 HH SCW/FT	4
5/16 PLAIN FLAT WASHER	4
5/16 SPLIT RING L WASHER	4

D

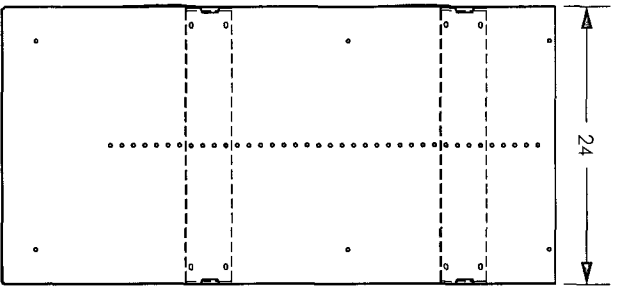

ITEM NO	PART NO	DESCRIPTION	QTY
1	FR60	FLOOR RAIL 60"	1
2	SF42460	SHELF 4X24X60	2
3	EP2448	KD End Panel 24x48	2
4	GS6X6	Gusset 6"	4

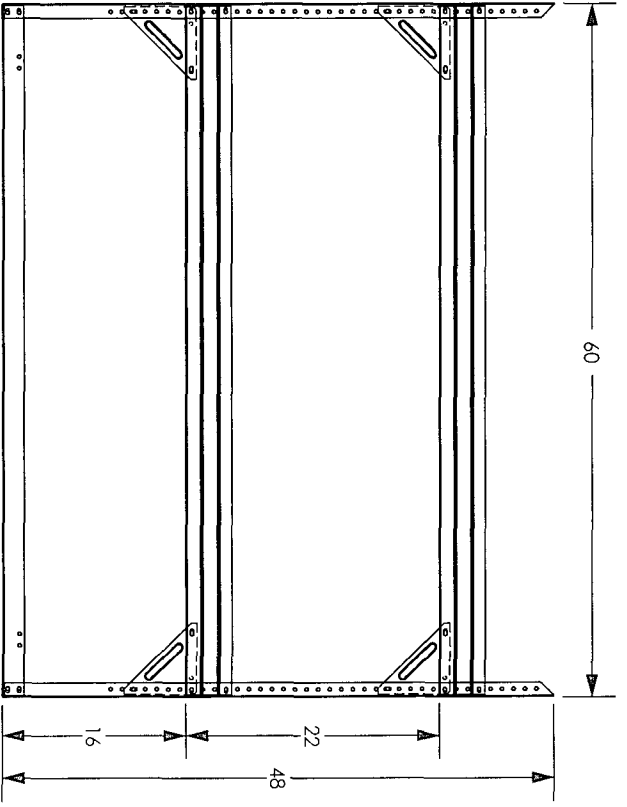
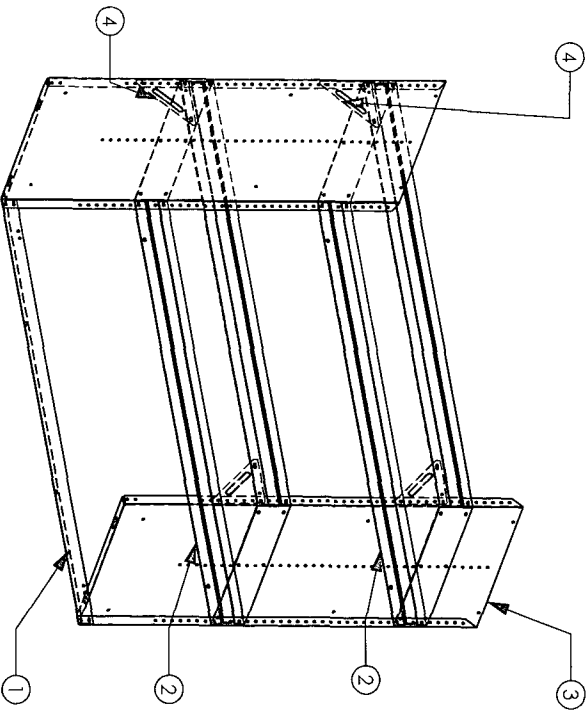

ADRIAN STEEL
 906 JAMES ST
 ADRIAN, MI 49221
 (517) 265-6194

THIS DRAWING IS THE PROPERTY OF ADRIAN STEEL CO.
 THIS DRAWING IS NOT TO BE USED IN ANY MANNER DETRIMENTAL TO THE INTERESTS OF ADRIAN STEEL CO

RELEASED CHK'D BDS
 EN-6071 7/2/02 BDS

REVISD CHK'D JLC
 EN-9288 6/09/06 JLC

REVISD CHK'D JLC
 EN-1100 3/10/08 RJB

Description:
 Remove 1/4-20 Fasteners for floor mounting and replace with 5/16-18 Plusnuts and Fasteners

D

STANDARD TOLERANCES UNLESS OTHERWISE NOTED:

- 0.0 = ± .125
- 0.00 = ± .062
- 0.000 = ± .031
- 0° = ± 2°
- 0.0° = ± 1°

Material Thickness = per AISI
 Notches, Slots, Holes = ± .015

MATERIAL:
 Area (Sq Ft) _____
 Weight (lbs) 122.33

FINISH: Gray Pwd.Ct.
 Coverage (Sq Ft) _____
 Weight (lbs) _____

DESIGNED BY **BDS** DRAWN BY **BDS** CHECKED BY **RLS**

SCALE: 1:16 DATE: 7/2/02

Part Description
KD SHELF UNIT 24x48x60
 (Straight back)

Size A REF: JD60FP
 Part Number **JD60FP** Issue **D**